

2023

CATALOGO **GENERALE** - GENERAL **CATALOGUE**

CATALOGO **GENERALE**
GENERAL **CATALOGUE**

Alldesign®

Alldesign⁺
plus

black & white

GLASSystem®

GLASSY

LAMINATO

LAMINATO *light*

MUSEUM

QUADRATUM

QUADRATUM^{frame}

TopLine 3

TopLine 9

METAL

Specials

ACCESSORI **OPTIONAL**

INDEX	PAGE
ALLdesign [®]	6
ALLdesign [®] plus	46
black & white	72
GLAS System [®]	106
GLASSY	140
LAMINATO	156
LAMINATO <i>light</i>	192
MUSEUM	244
QUADRATUM	294
QUADRATUM ^{frame}	320
TopLine 3	356
TopLine 9	378
TMETAL	392
Specials	420
ACCESSORI OPTIONAL	432



ALLdesign[®]



ALLdesign®



COM/AD1

ALLdesign[®]



COM/AD2



COM/AD3



COM/AD4

ALLdesign[®]

NB. ESEMPIO DI VETRINE H. 220 CM

E PIEDINI AL POSTO DELLE RUOTE

NB. EXAMPLE OF SHOWCASES H. 220 CM

AND FEET INSTEAD OF CASTORS



ALLdesign[®]



COM/AD5

COLORE STANDARD / STANDARD COLOUR

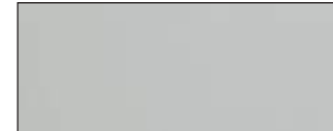

SILVER - LIGHT GREY

NB: PROFILI DI SERIE IN ALLUMINIO
NB: STANDARD ALLUMINIUM FRAME

NB: ALTRI COLORI A RICHIESTA
NB: OTHER COLOURS ON REQUEST

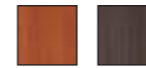

NB: CILIEGIO E WENGÈ DISPONIBILI FINO AD ESAURIMENTO SCORTE
NB: CHERRYWOOD AND WENGÈ AVAILABLE WHILE STOCKS LAST

ALLdesign[®]



Esempio di **art. 4/6** in colore ciliegio
Example of **art. 4/6** in cherry finish



Esempio di **art. 4/6** con quattro ripiani
Example of **art. 4/6** with four shelves

ALLdesign[®]



Esempio di art. 6/5 con quattro ripiani
Example of art. 6/5 with four shelves



» 22 _ art. 6/5 (cm 65x25x50h)



art. 6/5 BAR (cm 65x25x50h)

NB: apertura con n. 6 antine Basculanti (3 davanti + 3 dietro)
NB: opening with 6 tilting doors (3 on front + 3 on back)

ALLdesign®



Esempio di **art. 1/PF** con piantana in acciaio spazzolato
Example of **art. 1/PF** with brushed steel base



art. 6/TV (cm 45x45x42h)
misura interna teca cm 40x40x37h.
display case internal size cm 40x40x37h.



art. 1/TV (cm 101x51x26h) - Esempio colore wengè Example in wengè finish
art. 4/TV (cm 117x51x26h) - Esempio colore wengè Example in wengè finish
art. 5/TV (cm 160x80x26h) - Esempio colore wengè Example in wengè finish



misura interna teca cm 96x46x22h.
altezza base cm 73
display case internal size cm 96x46x22h.
base height cm 73



art. 4/PL
misura interna teca cm 113x46x22h.
altezza base cm 78
display case internal size cm 113x46x22h.
base height cm 78

art. 5/PL
misura interna teca cm 156x75x22h.
altezza base cm 78
display case internal size cm 156x75x22h.
base height cm 78



*misura interna teca cm 40x40x37h.
altezza base cm 110
display case internal size
cm 40x40x37h.
base height cm 110*

art. 2/PF (cm 45x45x153h)



*misura interna teca cm 40x40x79h.
altezza base cm 73
display case internal size
cm 40x40x79h.
base height cm 73*

art. 3/PF (cm 45x45x157h)



*misura interna teca cm 40x40x79h.
altezza base cm 110
display case internal size
cm 40x40x79h.
base height cm 110*

art. 4/PF (cm 45x45x195h)



Esempio di art. 6/PL senza ripiano
 Example of art. 6/PL without shelf

ALLdesign®



Interno di art. 6/PLA e 7/PLA
 Storage area of art. 6/PLA e 7/PLA



misura interna teca cm 40x40x37h.
 altezza base cm 90 senza anta
 display case internal size cm 40x40x37h.
 base height cm 90



misura interna teca cm 40x40x37h.
 altezza mobile cm 90
 2 ripiani, anta con serratura
 display case internal size
 cm 40x40x37h.
 cabinet height cm 90
 2 shelves, lockable door

art. 6/PL (cm 45x45x135h)

art. 6/PLA (cm 45x45x135h)



misura interna teca cm 40x40x79h.
 altezza base cm 90
 display case internal size cm 96x45x22h.
 base height cm 73



misura interna teca cm 40x40x79h.
 altezza mobile cm 90
 2 ripiani, anta con serratura
 display case internal size
 cm 40x40x37h.
 cabinet height cm 90
 2 shelves, lockable door



ESEMPIO DI ART. 7/PLA
 CON TRE FARETTI LATERALI
 (ART. 3/A ILLUMINAZIONE ALOGENA)
 (ART. 3/LD ILLUMINAZIONE A LED)
 EXAMPLE OF ART. 7/PLA
 WITH 3 SIDE LIGHTS
 (ART. 3/A HALOGEN LIGHTS)
 (ART. 3/LD LED LIGHTS)

ALLdesign[®]



ESEMPIO DI ART. 73/B O 93/B CON SCHIENALE IN LEGNO E PIEDINI ART. 4/PC
EXAMPLE OF ART. 73/B OR 93/B WITH WOODEN BACK PANEL AND FEET ART. 4/PC



art. 73/B (cm 73x39x92h)



art. 93/B (cm 93x39x92h)

ALLdesign[®]



(ESEMPIO DI ART. 70/B CON SCHIENALE IN LEGNO E PIEDINI ART. 4/PC)
(EXAMPLE OF ART. 70/B WITH WOODEN BACK PANEL AND FEET ART. 4/PC)



(ESEMPIO DI ART. 93/B CON MOBILE VERNICIATO, COLORE E H. A RICHIESTA)
(EXAMPLE OF ART. 93/B WITH PAINTED COUNTER, COLOUR AND HEIGHT ON REQUEST)



art. 70/B (cm 73x73x92h)



(ESEMPIO DI ABBINAMENTO TRA ART. 73/B - 70/B - 93/B)
(EXAMPLE OF ART. 73/B - 70/B - 93/B - COMPOSITION)

COLORE STANDARD / STANDARD COLOUR

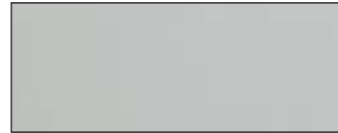

SILVER - LIGHT GREY

NB: PROFILI DI SERIE IN ALLUMINIO
NB: STANDARD ALLUMINIUM FRAME



NB: CILIEGIO E WENGÈ DISPONIBILI FINO AD ESAURIMENTO SCORTE
NB: CHERRYWOOD AND WENGÈ AVAILABLE WHILE STOCKS LAST



art. 53/14 (cm 53x39x141h)



art. 73/14 (cm 73x39x141h)
art. 93/14 (cm 93x39x141h)



art. 43/A (cm 43x43x180h) Base e top colore bianco
Base and Top in white colour

ESEMPIO DI ART. 93/A CON SCHIENALE IN LEGNO
EXAMPLE OF ART. 93/A WITH WOODEN BACK PANEL



art. 53/A (cm 53x39x180h)



art. 73/A (cm 73x39x180h)
art. 93/A (cm 93x39x180h)



art. 70/A (cm 73x73x180h)



art. 53/BL (cm 53x39x180h) - Esempio colore wengè
Example in wengè finish



art. 73/BL (cm 73x39x180h) - Esempio colore wengè
Example in wengè finish



art. 93/BL (cm 93x39x180h) - Esempio colore wengè
Example in wengè finish

MISURA MOBILE CM 53x39x43H.
LARGHEZZA INTERNA CM 48
ALTEZZA TOTALE DA TERRA CM 50
CABINET SIZE CM 53x39x43H.
INTERNAL WIDTH CM 48
TOTAL HEIGHT FROM
THE GROUND CM 50

MISURA MOBILE CM 73x39x43H.
LARGHEZZA INTERNA CM 68
ALTEZZA TOTALE DA TERRA CM 50
CABINET SIZE CM 73x39x43H.
INTERNAL WIDTH CM 68
TOTAL HEIGHT FROM
THE GROUND CM 50

MISURA MOBILE CM 93x39x43H.
LARGHEZZA INTERNA CM 88
ALTEZZA TOTALE DA TERRA CM 50
CABINET SIZE CM 93x39x43H.
INTERNAL WIDTH CM 88
TOTAL HEIGHT FROM
THE GROUND CM 50

ALLdesign®

MISURA MOBILE CM 73x73x43H.
ALTEZZA TOTALE DA TERRA CM 50
CABINET SIZE CM 73x73x43H.
TOTAL HEIGHT FROM
THE GROUND CM 50



art. 53/M (cm 53x39x180h)



art. 73/M (cm 73x39x180h)
art. 93/M (cm 93x39x180h)



art. 70/M (cm 73x73x180h)

MISURA MOBILE CM 53x39x43H.
LARGHEZZA INTERNA CM 48
ALTEZZA TOTALE DA TERRA CM 50
CABINET SIZE CM 53x39x43H.
INTERNAL WIDTH CM 48
TOTAL HEIGHT FROM
THE GROUND CM 50



art. 53/MA (cm 53x39x220h)

MISURA MOBILE CM 73x39x43H.
LARGHEZZA INTERNA CM 68
ALTEZZA TOTALE DA TERRA CM 50
CABINET SIZE CM 73x39x43H.
INTERNAL WIDTH CM 68
TOTAL HEIGHT FROM
THE GROUND CM 50



art. 73/MA (cm 73x39x220h)
art. 93/MA (cm 93x39x220h)

MISURA MOBILE CM 93x39x43H.
LARGHEZZA INTERNA CM 88
ALTEZZA TOTALE DA TERRA CM 50
CABINET SIZE CM 93x39x43H.
INTERNAL WIDTH CM 88
TOTAL HEIGHT FROM
THE GROUND CM 50



MISURA MOBILE CM 73x73x43H.
ALTEZZA TOTALE DA TERRA CM 50
CABINET SIZE CM 73x73x43H.
TOTAL HEIGHT FROM
THE GROUND CM 50

art. 70/MA (cm 73x73x220h)

ALLdesign[®]



ALLdesign⁺
plus



COM/AP1

COM/AP2

COLORE / COLOUR



BIANCO - WHITE

NB: PROFILI DI SERIE IN ALLUMINIO
COLORE BIANCO,
ALTRI COLORI A RICHIESTA.

NB: STANDARD ALLUMINIUM FRAME
IN WHITE FINISH,
OTHER COLOURS ON REQUEST.



art. 4/6P (cm 38x23x61h)



Esempio di art. 4/6P con quattro ripiani
Example of art. 4/6P with four shelves



art. 6/5P (cm 63x23x51h)



art. 6/5PB (cm 63x23x51h)

NB: apertura con n.6 antine basculanti
(n.3 davanti + n.3 dietro)
NB: opening with 6 tilting doors
(n.3 front + n.3 back)

COLORE PIANTANE / COLOUR PEDESTALS



ACCIAIO SPAZZOLATO - BRUSHED STEEL



COLORE SILVER - SILVER COLOUR



art. 1/PFP (cm 99x49x100h)

misura interna teca cm 95x45x22h.
altezza base cm 73
display case internal size cm 95x45x22h.
base height cm 73



art. 2/PFP (cm 43x43x152h)

misura interna teca cm 39x39x37h.
altezza base cm 110
display case internal size cm 39x39x37h.
base height cm 110



art. 3/PFP (cm 43x43x157h)

misura interna teca cm 39x39x79h.
altezza base cm 73
display case internal size cm 39x39x79h.
base height cm 73



art. 4/PFP (cm 43x43x194h)

misura interna teca cm 39x39x79h.
altezza base cm 110
display case internal size cm 39x39x79h.
base height cm 110



art. 4/PLP (cm 116x50x106h)
misura interna teca cm 112x45x22h.
altezza base cm 78
display case internal size cm 112x45x22h.
base height cm 78

art. 5/PLP (cm 159x78x106h)
misura interna teca cm 154x73x22h.
altezza base cm 78
display case internal size cm 154x73x22h.
base height cm 78

art. 1/TP (cm 99x49x27h)
misura interna teca cm 95x45x22h.
display case internal size cm 95x45x22h.



art. 4/TP (cm 116x50x27h)
misura interna teca cm 112x45x22h.
display case internal size cm 112x45x22h.

art. 5/TP (cm 159x78x27h)
misura interna teca cm 154x73x22h.
display case internal size cm 154x73x22h.



art. 6/PLP (cm 43x43x135h)



art. 6/LAP (cm 43x43x135h)



Interno di art. 6/LAP
Storage area of art. 6/LAP



art. 6/TP (cm 43x43x41h)
misura interna teca cm 39x39x37h.
display case internal size cm 39x39x37h.

Altezza mobile cm 90 con
2 ripiani, anta con serratura

Cabinet height cm 90 with
2 shelves, lockable door



art. 7/PLP (cm 43x43x177h)



art. 7/LAP (cm 43x43x177h)



ESEMPIO DI ART. 7/LAP
CON 2 STRISCE LED LATERALI
(ART. SL/9)
EXAMPLE OF ART. 7/LAP
WITH N.2 LED STRIPS LIGHTS
(ART. SL/9)

misura interna teca cm 39x39x79h.
altezza mobile cm 90 con
2 ripiani, anta con serratura
display case internal size
cm 39x39x79h.
cabinet height cm 90 with
2 shelves, lockable door



Interno di art. 7/LAP
Storage area of art. 7/LAP

COLORE / COLOUR



BIANCO - WHITE

NB: PROFILI DI SERIE IN ALLUMINIO
COLORE BIANCO,
ALTRI COLORI A RICHIESTA.

NB: STANDARD ALLUMINIUM FRAME
IN WHITE FINISH,
OTHER COLOURS ON REQUEST.



art. 71/BP (cm 71x37x90h)



art. 91/BP (cm 91x37x90h)



art. 51/14P (cm 51x37x140h)



art. 71/14P (cm 71x37x140h)
art. 91/14P (cm 91x37x140h)



art. 51/18P (cm 51x37x180h)



art. 71/18P (cm 71x37x180h)
art. 91/18P (cm 91x37x180h)



art. 51/MP (cm 51x37x180h)



art. 71/MP (cm 71x37x180h)
art. 91/MP (cm 91x37x180h)



art. 51/MAP (cm 51x37x220h)



art. 71/MAP (cm 71x37x220h)
art. 91/MAP (cm 91x37x220h)



ESEMPIO DI ART. 71/MAP CON ILLUMINAZIONE N°2 STRISCIE LED ART. SL/18
EXAMPLE OF ART. 71/MAP WITH 2 LED-STRIPE LIGHTINGS ART.SL/18



art. 71/12P (cm 71x37x120h)



art. 91/12P (cm 91x37x120h)



art. 51/17P (cm 51x37x170h)



art. 71/17P (cm 71x37x170h)
art. 91/17P (cm 91x37x170h)

NB: PIEDINI CROMO LUCIDO
NB: POLISHED CHROME LEGS



black & white



COM/BW1

black & white



COM/BW2



COM/BW3

black & white



COM/BW4

NB: Esempio in ecopelle cocodrillo marrone
NB: Example in brown crocodile imitation leather



Art. 50/B - cm 100x46x90h
Banco
Counter



Art. 50/TOP - cm 100x46x0,8
Top in cristallo satinato
Glazed glass top



Art. TOP/RE - cm 100x60x0,8
Top in cristallo satinato
Glazed glass top



Art. 40/TOP - cm 150x72x0,8
Top in cristallo satinato
Glazed glass top



Art. TOP/TT - cm 120x60x0,8
Top in cristallo satinato
Glazed glass top



Art. TOP/LT - cm 100x45/60x0,8
Top in cristallo satinato
Glazed glass top



art. 50/C
Cassettiera
Drawers



art. 50/MC
Mensola corta
Short shelf



art. 50/ML
Mensola lunga
Long shelf

STANDARD COLOUR



LACCATURA SILVER - LIGHT GREY LAQUER

black & white



art. 50/B (cm 100 x 46 x 90h) + 50/TOP + 50/C + 50/MC



art. 50/B (cm 100 x 46 x 90h) + 2 art. 50/ML



Esempio in ecopelle cromo
 Example in chrome imitation leather finish
art. 10/B (cm 100 x 46 x 90h)



Esempio in ecopelle coccodrillo marrone
 Example in brown crocodile imitation leather finish
art. 10/B (cm 100 x 46 x 90h)

black & white



Esempio in ecopelle cromo
 Example in chrome imitation leather finish
art. 10/B (cm 100 x 46 x 90h) + 2 **art. 50/ML**



Esempio in ecopelle coccodrillo marrone
 Example in brown crocodile imitation leather finish
art. 10/B (cm 100 x 46 x 90h) + **50/C** + **50/MC**

STANDARD COLOUR



LACCATURA SILVER - LIGHT GREY LAQUER

FINITURE FINO AD ESAURIMENTO SCORTE / FINISHES WHILE STOCKS LAST



CILIEGIO - CHERRY-WOOD



ROVERE SBIANCATO - LIGHT OAK

NB: prezzi speciali fino ad esaurimento scorte
NB: Special prices up while stocks last

FINITURA ECOPELLE / IMITATION LEATHER FINISH



CROMO
CHROME



COCCODRILLO MARRONE
BROWN CROCODILE



COCCODRILLO BIANCO
WHITE CROCODILE

black & white



ESEMPIO ART. 140/B CON FINITURA ECOPELLE COCCODRILLO BIANCO, ART. 14/B
EXAMPLES OF ART. 140/B IN WHITE COCODRILE IMITATION LEATHER FINISH, ART. 14/B



» 86 _ art. 90/B (cm 93x46x90h) Con finitura Ecopelle Cromo, Coccodrillo Bianco, Coccodrillo Marrone art. 9/B
In Imitation Leather Finish Chorome, White Crocodile, Brown Crocodile art. 9/B



art. 140/B (cm 143x46x90h) Con finitura Ecopelle Cromo, Coccodrillo Bianco, Coccodrillo Marrone art. 14/B
In Imitation Leather Finish Chorome, White Crocodile, Brown Crocodile art. 14/B

black & white



ESEMPIO ART. 180/B CON FINITURA ECOPELLE COCCODRILLO MARRONE, ART. 18/B
 EXAMPLES OF ART. 180/B IN BROWN COCODRILE IMITATION LEATHER FINISH, ART. 18/B



black & white



art. 251/M (cm 93/44x43x200h)

ESEMPI ART. 251/M CON FINITURA ECOPELLE CROMO,
COCCODRILLO MARRONE ART. 9/TR
EXAMPLES OF ART. 251/M IN CHROME,
BROWN CROCODILE IMITATION LEATHER FINISH, ART. 9/TR



black & white



art. 50/S (cm 54x53x200h)

ESEMPI ART. 50/S CON FINITURA ECOPELLE CROMO,
COCCODRILLO MARRONE ART. 5/S
EXAMPLES OF ART. 50/S IN CHROME, BROWN CROCODILE,
IMITATION LEATHER FINISH, ART. 5/S



black & white



art. 90/S (cm 93x53x200h)

ESEMPI ART. 90/S CON FINITURA ECOPELLE CROMO,
E COCCODRILLO BIANCO ART. 9/S
EXAMPLES OF ART. 90/S IN CHROME, WHITE CROCODILE
IMITATION LEATHER FINISH, ART. 9/S





art. 90/SA (cm 93x53x200h)

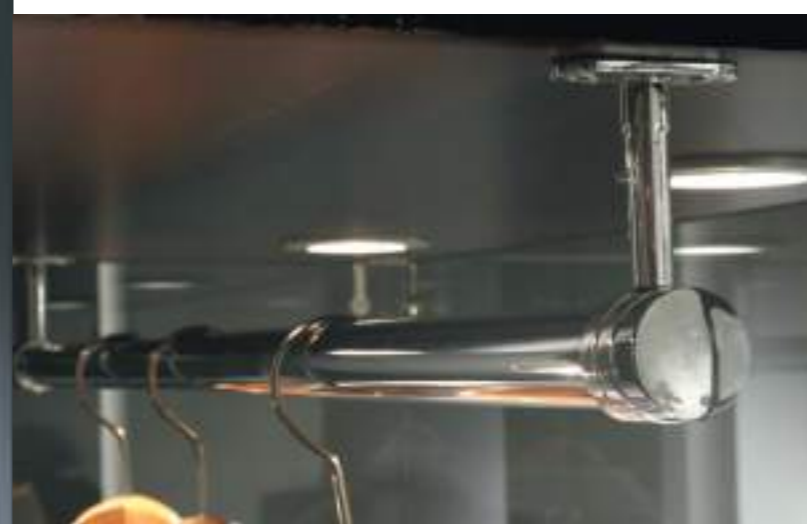

black & white

ESEMPI ART. 90/SA CON FINITURA ECOPELLE CROMO,
COCCODRILLO MARRONE ART. 9/SA
EXAMPLES OF ART. 90/SA IN CHROME, BROWN CROCODILE,
IMITATION LEATHER FINISH, ART. 9/SA





art. 90/SM (cm 93x53x200h)



black & white

ESEMPI ART. 90/SM CON FINITURA ECOPELLE CROMO, COCCODRILLO MARRONE
E COCCODRILLO BIANCO ART. 9/SM
EXAMPLES OF ART. 90/SM IN CHROME, BROWN CROCODILE, WHITE CROCODILE
IMITATION LEATHER FINISH, ART. 9/SM



ESEMPIO ART. 50/G CON FINITURA ECOPELLE
COCCODRILLO BIANCO ART. 5/G
EXAMPLE OF ART. 50/G WHITE CROCODILE IMITATION
LEATHER FINISH ART. 5/G



art. 140/S (cm 143x53x200h)

Con finitura Ecopelle Cromo, Coccodrillo Bianco, Coccodrillo Marrone art. 14/S
In Imitation Leather Finish Chrome, White Crocodile, Brown Crocodile art. 14/S



art. 50/G (cm 54x53x200h) vetrina con ripiani girevoli elettricamente





black & white

ESEMPI ART. 90/G CON FINITURA ECOPELLE CROMO,
 COCCODRILLO BIANCO E MARRONE ART. 9/G
 EXAMPLES OF ART. 90/G IN CHROME, WHITE CROCODILE, BROWN CROCODILE
 IMITATION LEATHER FINISH, ART. 9/G



art. 90/G (cm 93x53x200h) vetrina con ripiani girevoli elettricamente



art. 140/G (cm 143x53x200h) vetrina con ripiani girevoli elettricamente
Con finitura Ecopelle Cromo, Coccodrillo Bianco, Coccodrillo Marrone **art. 14/G**
In Imitation Leather Finish Chrome, White Crocodile, Brown Crocodile **art. 14/G**



art. 201/GB (cm Ø74x200h) vetrina con ripiani girevoli elettricamente



ESEMPIO CON FINITURA ECOPELLE COCCODRILLO MARRONE, ANCHE IN COCCODRILLO BIANCO E CROMO **ART. 7/G**
EXAMPLE IN BROWN CROCODILE, ALSO IN WHITE CROCODILE, CHROME IMITATION LEATHER FINISH **ART. 7/G**



GLASSystem®

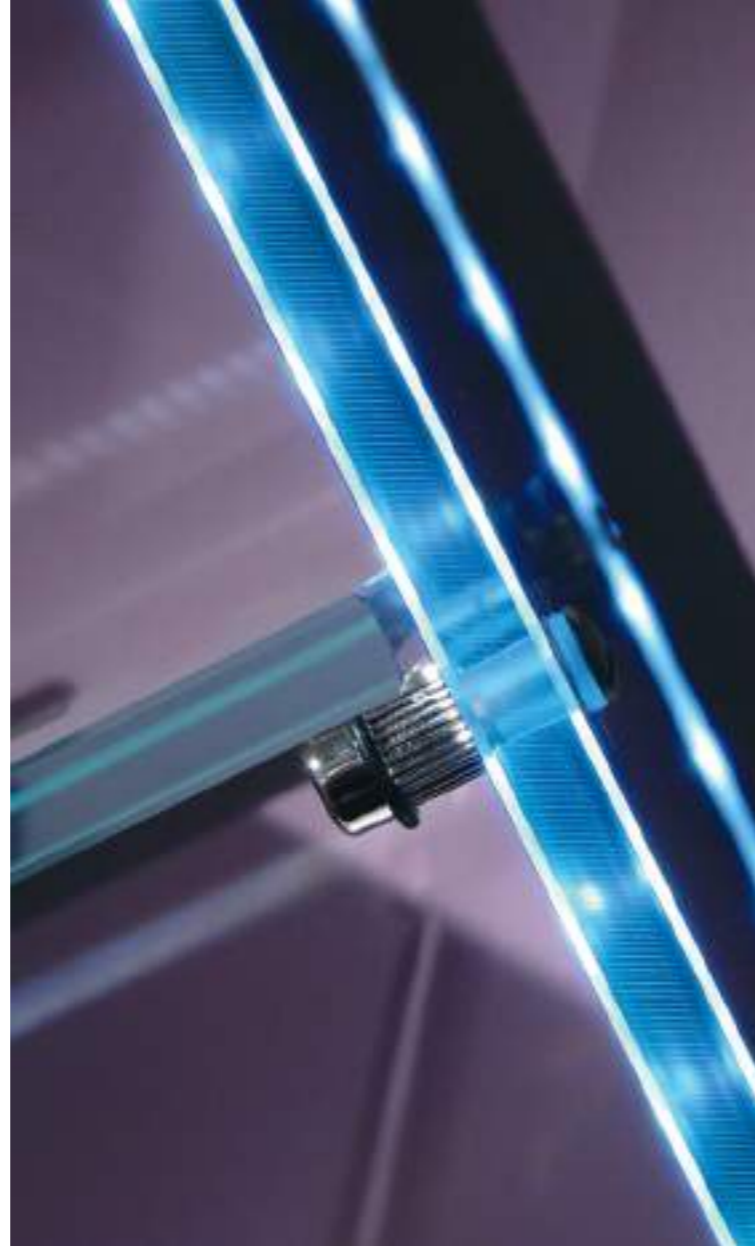

COM/GS4
 CM. 123 x 40 x 220H



← **COM/GS1**
 CM. 243 x 40 x 220H



COM/GS2
 CM. 243 x 40 x 140H

COM/GS3
 CM. 303 x 40 x 100H

GLASSystem®



COM/GS5
cm. 303 x 40 x 220H

GLASSystem®



COM/GS6
CM. 203 x 40 x 220H



COM/GS7
см. 203 x 80 x 100H

COM/GS8
см. 503 x 40 x 220H



GLASSystem®



COM/GS12
CM. 243 x 40 x 220H

COM/GS13
CM. 283 x 40 x 140H

GLASSystem®

FINITURE LEGNO DI SERIE
STANDARD WOOD FINISHES



BIANCO LUCIDO
GLOSSY WHITE

FINITURE LEGNO OPTIONAL
OPTIONAL WOOD FINISHES



WENGÉ WENGÉ ROVERE ★ OAK BAMBÙ ★ BAMBOO ALLUMINIO ★ ALUMINUM OSB ★ OSB ANTRACITE ★ CHARCOAL BETON ★ BETON VINTAGE ★ VINTAGE MADREPERLA ★ MOTHER-OF-PEARL NERO OPACO MATT BLACK

NB: ★ VENATURE LEGNO IN RILIEVO
NB: ★ EMBOSSED WOOD GRAINS

MODEL
ELEMENTI PER COMPOSIZIONI MURALI
ELEMENTS FOR WALL COMPOSITIONS

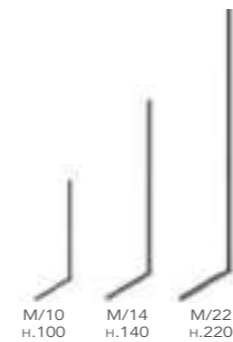
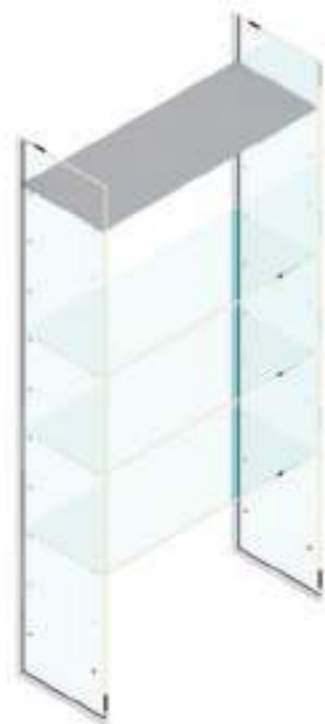

M/10
H.100 M/14
H.140 M/22
H.220
PROFILO PORTANTE IN
CROMO LUCIDO
SUPPORTING POLISHED

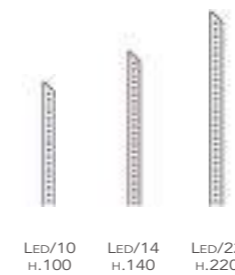

LED/10
H.100 LED/14
H.140 LED/22
H.220
ILLUMINAZIONE A LED
NELLA STRUTTURA
INTEGRATED LED LIGHT

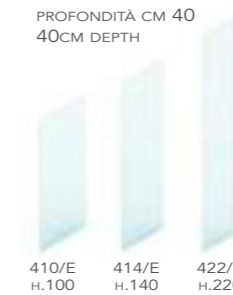

PROFONDITÀ CM 40
40CM DEPTH
410/E
H.100 414/E
H.140 422/E
H.220
SPALLE IN CRISTALLO
EXTRACHIARO
EXTRACLEAR GLASS SIDES

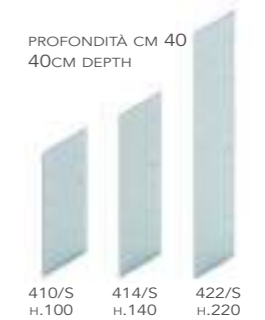

PROFONDITÀ CM 40
40CM DEPTH
410/S
H.100 414/S
H.140 422/S
H.220
SPALLE IN CRISTALLO
EXTRACHIARO SATINATO
GLAZED EXTRACLEAR

FINITURE LEGNO DI SERIE
STANDARD WOOD FINISHES



BIANCO LUCIDO
GLOSSY WHITE

MENSOLE IN CRISTALLO EXTRACHIARO EXTRACLEAR GLASS	MENSOLE IN CRISTALLO EXTRACHIARO SATINATO EXTRACLEAR GLAZED	MENSOLE IN LEGNO WOODEN SHELVES	MENSOLE IN LEGNO CON FORI DI FISSAGGIO WOODEN SHELVES WITH FIXING HOLES	MOBILI E ACCESSORI COUNTERS AND
RC/38 38x38	RC/38 S 38x38	ML/10 100x38	ML/10F 100x38	VG/10 100x38 h20 VANO A GIORNO PICCOLO SMALL OPEN COMPARTMENT
RC/10 100x38	RC/10 S 100x38	ML/12 120x38	ML/12F 120x38	VC/10 100x38 h20 VANO CON CASSETTO DRAWER COMPARTMENT
RC/12 120x38	RC/12 S 120x38	ML/14 140x38	ML/14F 140x38	BG/10 100x38 h60 VANO A GIORNO GRANDE BIG OPEN COMPARTMENT
RC/14 140x38	RC/14 S 140x38		TA/10 100 *SOLO CON ML/10F *WITH ML/10F ONLY	CS/5 50x38 h60 *CASSETTIERA PER BG/10 *DRAWER FOR BG/10
			TA/12 120 *SOLO CON ML/12F *WITH ML/12F ONLY	MB/5 50x38 *MENSOLA PER BG/10 CON CS/5 *SHELF FOR BG/10 WITH CS/5
			TA/14 140 *SOLO CON ML/14F *WITH ML/14F ONLY	MB/10 100x38 *MENSOLA PER BG/10 *SHELF FOR BG/10
				AN/5 50 h60 *ANTINA PER BG/10 *DOOR FOR BG/10

*TUBO APPENDIBITTI (ESEMPIO A PAG. 283)

*CLOTHES RAIL (EXAMPLE ON PAGE 283)

ELEMENTI PER COMPOSIZIONI AUTOPORTANTI
ELEMENTS FOR SELF-STANDING COMPOSITIONS

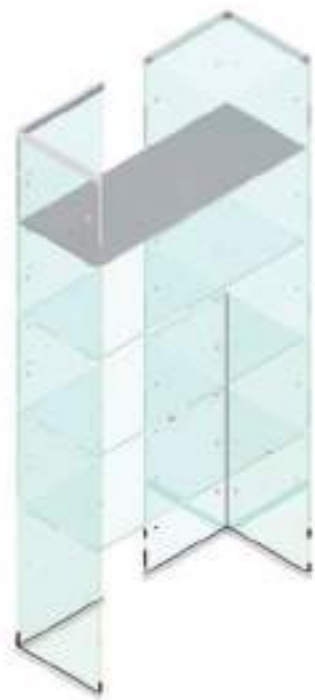

SUPPORTI IN CROMO LUCIDO
POLISHED CHROME SUPPORTS

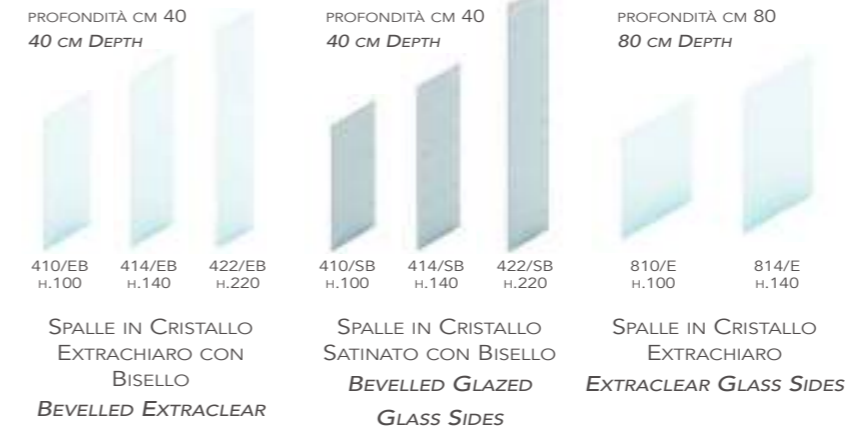

FINITURE LEGNO DI SERIE
STANDARD WOOD FINISHES

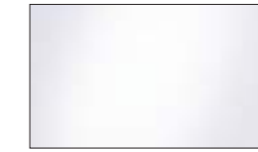

BIANCO LUCIDO
GLOSSY WHITE

MENSOLE IN CRISTALLO EXTRACHIARO EXTRACLEAR GLASS	MENSOLE IN CRISTALLO EXTRACHIARO SATINATO EXTRACLEAR GLAZED	MENSOLE IN LEGNO WOODEN SHELVES	MENSOLE IN LEGNO CON FORI DI FISSAGGIO WOODEN SHELVES WITH	MOBILI E ACCESSORI COUNTERS AND
RC/38 38x38	RC/38 S 38x38	ML/10 100x38	ML/10F 100x38	VG/10 100x38 h20 VANO A GIORNO PICCOLO SMALL OPEN COMPARTMENT
RC/10 100x38	RC/10 S 100x38	ML/12 120x38	ML/12F 120x38	VC/10 100x38 h20 VANO CON CASSETTO DRAWER COMPARTMENT
RC/12 120x38	RC/12 S 120x38	ML/14 140x38	ML/14F 140x38	BG/10 100x38 h60 VANO A GIORNO GRANDE BIG OPEN COMPARTMENT
RC/14 140x38	RC/14 S 140x38	RAL/10 100x80	IA/10 100 *SOLO CON ML/10F *WITH ML/10F ONLY	CS/5 50x38 h60 *CASSETTIERA PER BG/10 *DRAWER FOR BG/10
RAC/10 100x80	RAC/10 S 100x80	RAL/12 120x80	TA/12 120 *SOLO CON ML/12F *WITH ML/12F ONLY	MB/5 50x38 *MENSOLA PER BG/10 CON CS/5 *SHELF FOR BG/10 WITH CS/5
RAC/12 120x80	RAC/12 S 120x80	RAL/14 140x80	TA/14 140 *SOLO CON ML/14F *WITH ML/14F ONLY	MB/10 100x38 *MENSOLA PER BG/10 *SHELF FOR BG/10
RAC/14 140x80	RAC/14 S 140x80			AN/5 50 h60 *ANTINA PER BG/10 *DOOR FOR BG/10

*TUBO APPENDIABITI (ESEMPIO A PAG. 283)

*CLOTHES RAIL (EXAMPLE ON PAGE 283)

GLASSystem®

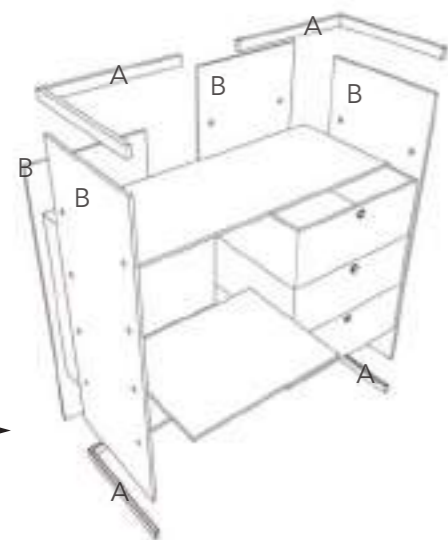

5

cm. 103 x 40 x 100H

SCHEMA DI COMPONENTI VANO GIORNO GRANDE ART. BG/10:

- FIG. 1 - ART. BG/10 VANO GIORNO GRANDE
- FIG. 2 - ART. BG/10 CON 2 ART. AN/5
- FIG. 3 - ART. BG/10 CON 1 ART. CS/5 E 1 ART. AN/5
- FIG. 4 - ART. BG/10 CON 2 ART. CS/5
- FIG. 5 - ART. BG/10 CON 1 ART. CS/5 E 1 ART. MB/5
- FIG. 6 - ART. BG/10 CON 1 ART. VC/10 E 2 ART. AN/5
- FIG. 7 - ART. BG/10 CON 1 ART. VC/10, 1 ART. AN/5 E 1 ART. MB/5
- FIG. 8 - ART. BG/10 CON 1 ART. VC/10 E 1 ART. MB/10
- FIG. 9 - ART. VC/10 E 2 ART. RC/10

LA STRUTTURA PORTANTE IN CRISTALLO È REALIZZATA CON I SEGUENTI ARTICOLI:

- A - N° 2 ART. L/2 PROFILI CROMO
- B - N° 4 ART. 410/EB SPALLE CON BISELLO A 45°

ASSEMBLING SCHEME OF THE BIG OPEN COMPARTMENT ART. BG/10:

- IMG. 1 - ART. BG/10 BIG OPEN COMPARTMENT
- IMG. 2 - ART. BG/10 WITH 2 ART. AN/5
- IMG. 3 - ART. BG/10 WITH 1 ART. CS/5 AND 1 ART. AN/5
- IMG. 4 - ART. BG/10 WITH 2 ART. CS/5
- IMG. 5 - ART. BG/10 WITH 1 ART. CS/5 AND 1 ART. MB/5
- IMG. 6 - ART. BG/10 WITH 1 ART. VC/10 AND 2 ART. AN/5
- IMG. 7 - ART. BG/10 WITH 1 ART. VC/10, 1 ART. AN/5 AND 1 ART. MB/5
- IMG. 8 - ART. BG/10 WITH 1 ART. VC/10 AND 1 ART. MB/10
- IMG. 9 - ART. VC/10 AND 2 ART. RC/10

THE BEARING GLASS STRUCTURE WAS MADE WITH THE FOLLOWING COMPONENTS:

- A - N° 2 ART. L/2 CHROME FRAMES
- B - N° 4 ART. 410/EB BEVELLED GLASS SIDE A 45°

NB: UTILIZZANDO IL PROFILO A T (ART. T/2) LA COMPOSIZIONE DIVENTA BIFACCIALE E QUINDI NEL LATO OPPOSTO SI POSSONO METTERE SIA ALTRI MOBILI CHE RIPIANI IN CRISTALLO O IN LEGNO.

NB: BY USING THE T-SHAPED PROFILE (ART. T/2), A DOUBLE-SIDED COMPOSITION IS OBTAINABLE, OFFERING THE OPPORTUNITY OF ADDING EITHER OTHER COUNTERS AND GLASS OR WOODEN SHELVES.



COM/GS15



5

COM/GS14

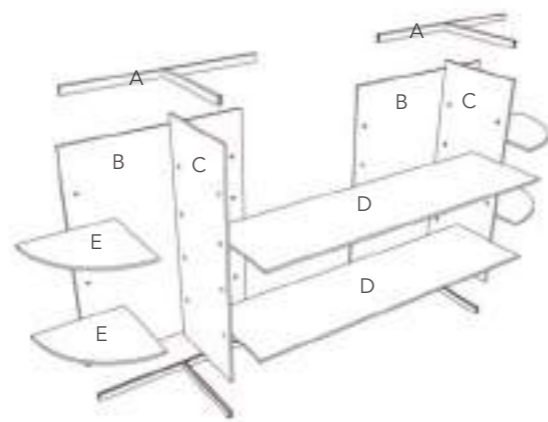

CM. 203 x 40 x 100H

SCHEMA DI COMPONENTI PER COMPOSIZIONE AUTOPORTANTE:

- A - N° 2 ART. T/2 PROFILI CROMO
- B - N° 2 ART. 810/E SPALLE CM.80x100
- C - N° 2 ART. 410/E SPALLE CM.40x100
- D - N° 2 ART. RC/12 RIPIANI IN CRISTALLO CM.38x120
- E - N° 4 ART. RC/38 RIPIANI IN CRISTALLO CM.38x38

ASSEMBLING SCHEME OF SELF-STANDING COMPOSITION:

- A - N° 2 ART. T/2 CHROME FRAMES
- B - N° 2 ART. 810/E CM.80x100 SIDES
- C - N° 2 ART. 410/E CM.40x100 SIDES
- D - N° 2 ART. RC/12 CM.38x120 GLASS SHELVES



GLASSystem®

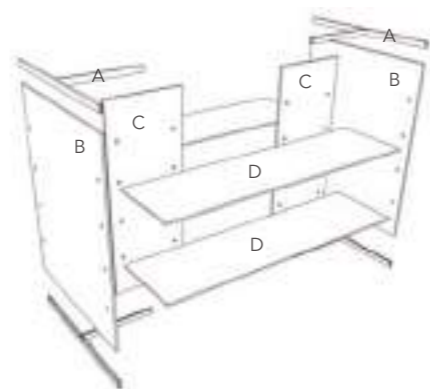

CM. 143 x 80 x 100H

SCHEMA DI COMPONENTI PER COMPOSIZIONE AUTOPORTANTE:

- A - N° 2 ART. T/2 PROFILI CROMO
- B - N° 2 ART. 810/E SPALLE CM.80x100
- C - N° 2 ART. 410/E SPALLE CM.40x100
- D - N° 4 ART. RC/14 RIPIANI IN CRISTALLO CM.38x140

ASSEMBLING SCHEME OF SELF-STANDING COMPOSITION:

- A - N° 2 ART. T/2 CHROME FRAMES
- B - N° 2 ART. 810/E CM.80x100 SIDES
- C - N° 2 ART. 410/E CM.40x100 SIDES
- D - N° 4 ART. RC/14 CM.38x140 GLASS SHELVES



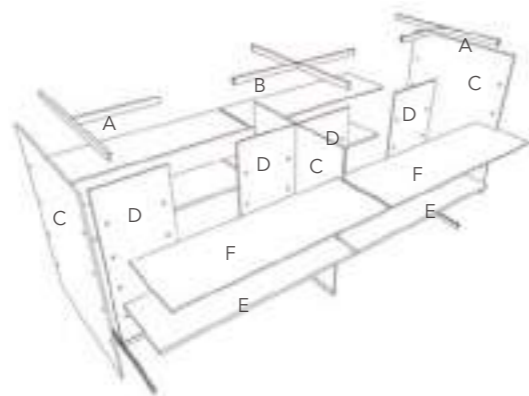

cm. 203 x 80 x 100H

SCHEMA DI COMPONENTI PER COMPOSIZIONE AUTOPORTANTE:

- A - N° 2 ART. T/2 PROFILI CROMO
- B - N° 1 ART. CR/2 PROFILI CROMO
- C - N° 3 ART. 810/E SPALLE CM. 80x100
- D - N° 4 ART. 410/E SPALLE CM.40x100
- E - N° 4 ART. ML/10 MENSOLA LEGNO CM.38x100
- F - N° 4 ART. RC/10 RIPIANI IN CRISTALLO CM.38x100

ASSEMBLING SCHEME OF SELF-STANDING COMPOSITION:

- A - N° 2 ART. T/2 CHROME FRAMES
- B - N° 1 ART. CR/2 CHROME FRAMES
- C - N° 3 ART. 810/E CM. 80x100 SIDES
- D - N° 4 ART. 410/E CM.40x100 SIDES
- E - N° 4 ART. ML/10 CM.38x100 WOODEN SHELVES

GLASSystem®

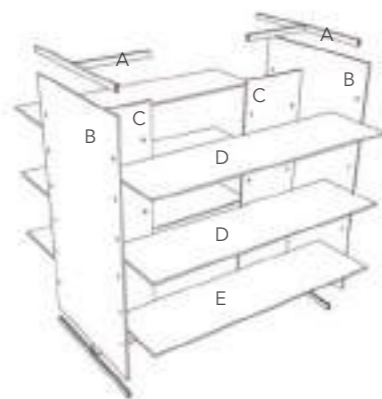

cm. 123 x 80 x 140H

SCHEMA DI COMPONENTI PER COMPOSIZIONE AUTOPORTANTE:

- A - N° 2 ART. T/2 PROFILI CROMO
- B - N° 2 ART. 814/E SPALLE CM. 80x140
- C - N° 2 ART. 414/E SPALLE CM. 40x140
- D - N° 4 ART. RC/12 RIPIANI IN CRISTALLO CM.38x120
- E - N° 2 ART. ML/12 RIPIANO IN LEGNO CM.38x120

ASSEMBLING SCHEME OF SELF-STANDING COMPOSITION:

- A - N° 2 ART. T/2 CHROME FRAMES
- B - N° 2 ART. 814/E CM. 80x140 SIDES
- C - N° 2 ART. 414/E CM. 40x140 SIDES
- D - N° 4 ART. RC/12 CM. 38x120 GLASS SHELVES



COM/GS18



COM/GS19

GLASSystem®

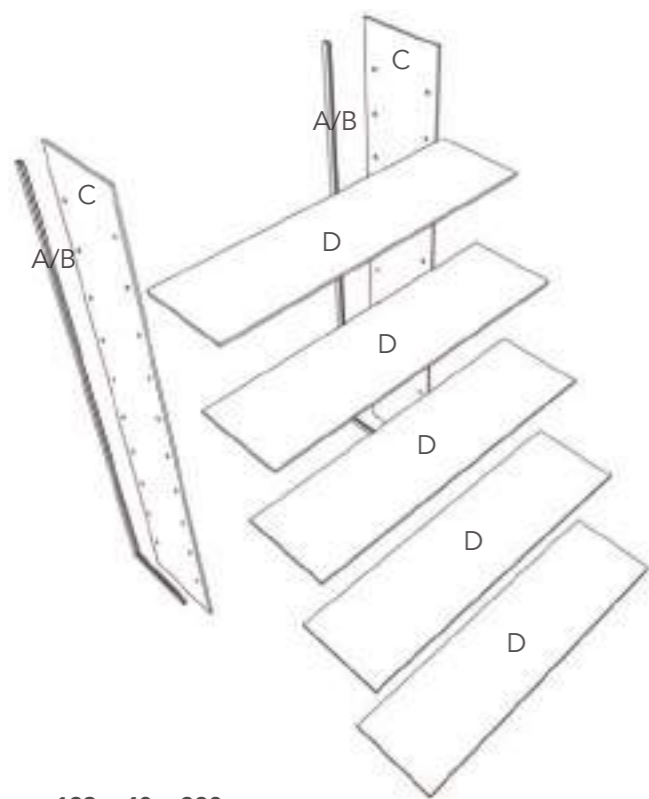

cm. 123 x 40 x 220H

SCHEMA DI COMPONENTI PER COMPOSIZIONE MURALE:

- A - N° 2 ART. M/22 PROFILI CROMO
- B - N° 2 ART. LED/22 LUCI LED
- C - N° 2 ART. 422/E SPALLE CM.40x220
- D - N° 5 ART. RC/12 RIPIANI IN CRISTALLO CM.38x120

ASSEMBLING SCHEME OF WALL COMPOSITION:

- A - N° 2 ART. M/22 CHROME FRAMES
- B - N° 2 ART. LED/22 LED LIGHTS
- C - N° 2 ART. 422/E CM.40x220 SIDES
- D - N° 5 ART. RC/12 CM.38x120 GLASS SHELVES



COM/GS20

NB: L'IMPIANTO ELETTRICO È DIETRO AL MURO

NB: THE ELECTRICAL WIRING IS BEHIND THE WALL

GLASSystem®

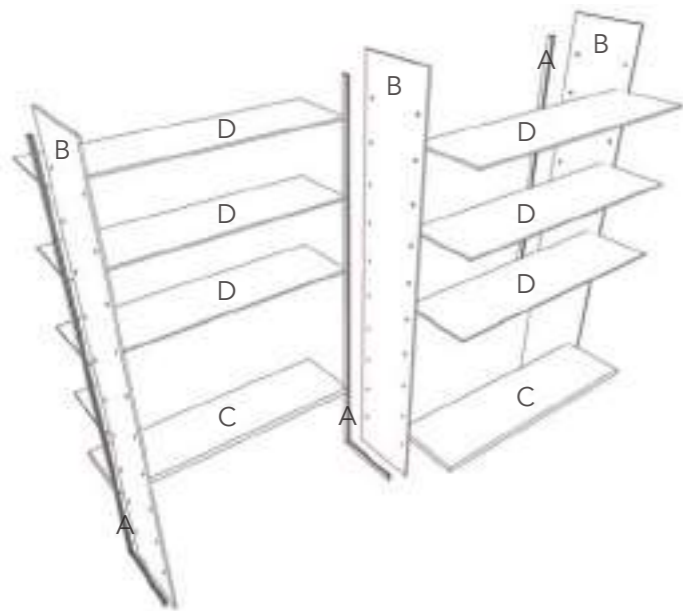

cm. 203 x 40 x 220H

**SCHEMA DI COMPONIBILITÀ PER COMPOSIZIONE MURALE
CON SPALLE E RIPIANI IN CRISTALLO SATINATO:**

- A - N° 3 ART. M/22 PROFILI CROMO
- B - N° 3 ART. 422/S SPALLE SATINATE CM.40x220
- C - N° 2 ART. ML/10 RIPIANO LEGNO CM.38x100
- D - N° 6 ART. RC/10 RIPIANI IN CRISTALLO CM.38x100

ASSEMBLING SCHEME OF WALL COMPOSITION WITH GLAZED

GLASS SIDES AND SHELVES:

- A - N° 3 ART. M/22 CHROME FRAMES
- B - N° 3 ART. 422/S CM.40x220 GLAZED SIDES
- C - N° 2 ART. ML/10 CM.38x100 WOODEN SHELVES



COM/GS21

GLASSystem®

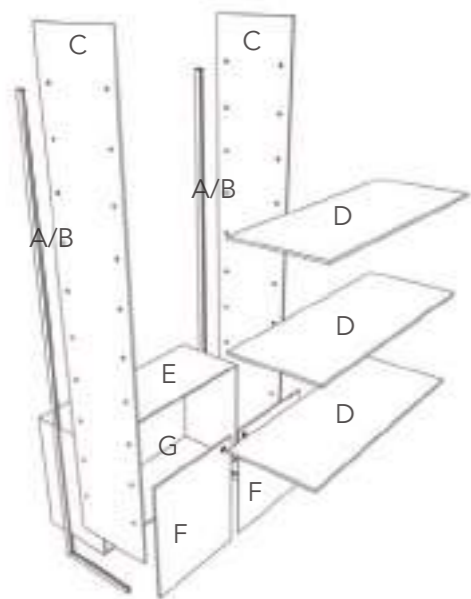

cm. 103 x 40 x 220h

SCHEMA DI COMPONENTI PER COMPOSIZIONE MURALE:

- A - N° 2 ART. M/22 PROFILI CROMO
- B - N° 2 ART. LED/22 LUCI LED
- C - N° 2 ART. 422/E SPALLE CM.40x220
- D - N° 3 ART. RC/10 RIPIANI IN CRISTALLO CM.38x100
- E - N° 1 ART. BG/10 VANO A GIORNO
- F - N° 2 ART. AN/5 ANTINE CON SERRATURA
- G - N° 1 ART. MB/10 MENSOLA INTERNA

ASSEMBLING SCHEME OF WALL COMPOSITION:

- A - N° 2 ART. M/22 CHROME FRAMES
- B - N° 2 ART. LED/22 LIGHTS
- C - N° 2 ART. 422/E SIDES CM.40x220
- D - N° 3 ART. RC/10 GLASS SHELVES CM.38x100
- E - N° 1 ART. BG/10 OPEN COMPARTMENT
- F - N° 2 ART. AN/5 LOCKABLE DOORS



COM/GS22

GLASSystem®

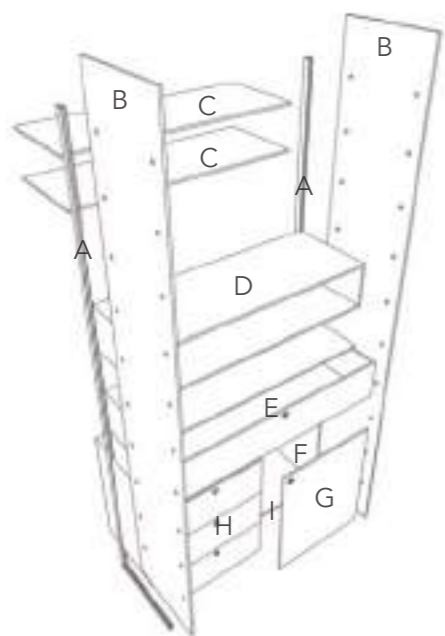

cm. 103 x 40 x 220H

SCHEMA DI COMPONIBILITÀ PER COMPOSIZIONE MURALE:

- A - N° 2 ART. M/22 PROFILI CROMO
- B - N° 2 ART. 422/E SPALLE CM.40x220
- C - N° 2 ART. RC/10 RIPIANI IN CRISTALLO CM.38x100
- D - N° 1 ART. VG/10 VANO A GIORNO
- E - N° 1 ART. VC/10 CASSETTO
- F - N° 1 ART. BG/10 VANO A GIORNO
- G - N° 1 ART. AN/5 ANTA CON SERRATURA
- H - N° 1 ART. CS/5 CASSETTIERA
- I - N° 1 ART. MB/5 MENSOLA INTERNA

ASSEMBLING SCHEME OF WALL COMPOSITION:

- A - N° 2 ART. M/22 CHROME FRAMES
- B - N° 2 ART. 422/E SIDES CM.40x220
- C - N° 2 ART. RC/10 GLASS SHELVES CM.38x100
- D - N° 1 ART. VG/10 OPEN COMPARTMENT
- E - N° 1 ART. VC/10 DRAWER
- F - N° 1 ART. BG/10 OPEN COMPARTMENT
- G - N° 1 ART. AN/5 LOCKABLE DOOR
- H - N° 1 ART. CS/5 DRAWERS



COM/GS23

FINITURE LEGNO DI SERIE
STANDARD WOOD FINISHES



BIANCO LUCIDO
GLOSSY WHITE

FINITURE LEGNO OPTIONAL
OPTIONAL WOOD FINISHES

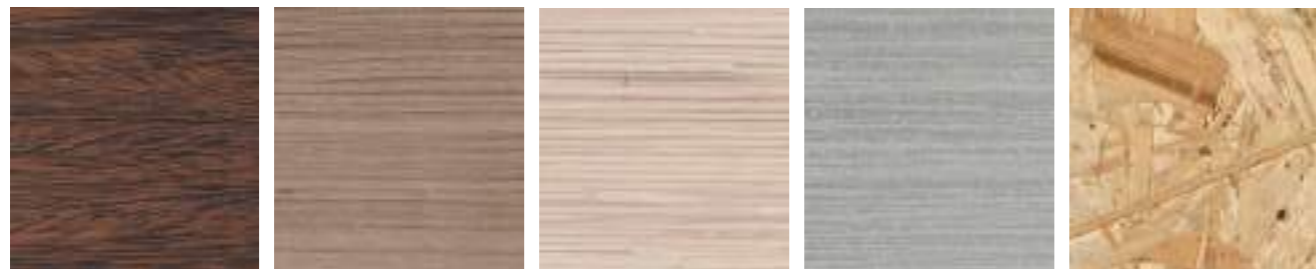

WENGÈ
WENGÈ

ROVERE ★
OAK

BAMBÙ ★
BAMBOO

ALLUMINIO ★
ALUMINIUM

OSB ★
OSB

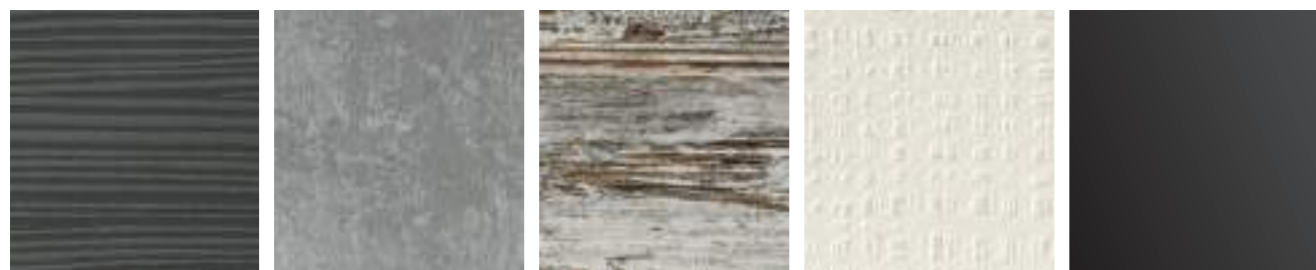

ANTRACITE ★
CHARCOAL

BETON ★
BETON

VINTAGE ★
VINTAGE

MADREPERLA ★
MOTHER-OF-PEARL

NERO OPACO
MATT BLACK

NB: ★ VENATURE LEGNO IN RILIEVO
NB: ★ EMBOSSED WOOD GRAINS

ESEMPIO DI CRISTALLO STRATIFICATO CON INSERIMENTO DI TESSUTO
EXAMPLE OF LAMINATED GLASS WITH FABRIC INSERTIONS

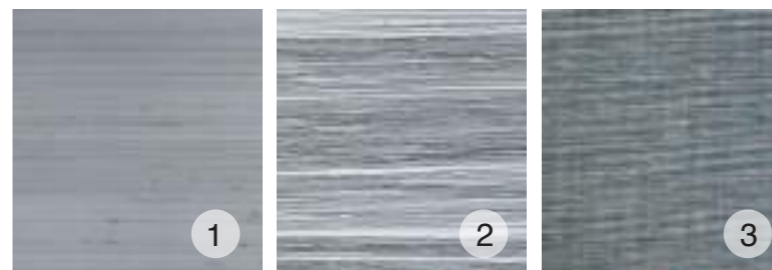

TESSUTO LINO
LINEN FABRIC

FILI DI COTONE
COTTON STRINGS

TESSUTO A RETE
FISHNET FABRIC

ESEMPIO DI CRISTALLO LACCATO CON TINTE RAL
EXAMPLE OF LACQUERED GLASS WITH RAL FINISHES

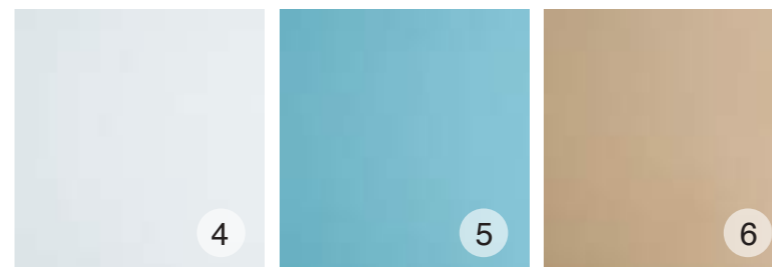

BIANCO RIF.349
WHITE RIF.349

AZZURRO RIF.5024
LIGHT BLUE RIF.5024

BEIGE RIF.1019
BEIGE RIF.1019



ROSSO RIF.3020
RED RIF.3020

NERO RIF.8052
BLACK RIF.8052

GRIGIO RIF.7025
SILVER RIF.7025





GLASSY



COM/GL1



COM/GL2



COM/GL3





art. GL/5BC (cm 60x46x95h)



art. GL/10B (cm 100x46x95h)
Stiscia led sotto il top
Led strip under the top



art. GL/10BG (cm 100x46x95h)
Stiscia led sotto il top
Led strip under the top

Esempio di art. GL/10BG
Example of art. GL/10BG

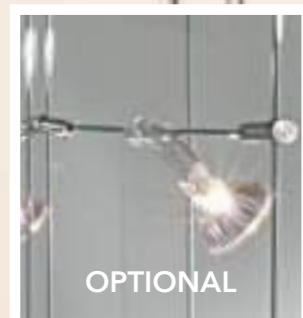

Esempio di illuminazione
laterale per ogni ripiano
*Example of side lighting
for each shelf*





LAMINATO



COM/LA1



COM/LA2



LAMINATO



COM/LA3





COM/LA4

LAMINATO



COM/LA5

LAMINATO

COLORE / COLOUR

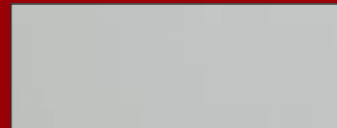

SILVER - LIGHT GREY



art. 201/Q (cm 31x31x74h)



art. 201/RQ (cm 31x31x74h)



art. 221/E (cm Ø36x74h)



art. 221/ER (cm Ø36x74h)

LAMINATO

COLORE / COLOUR

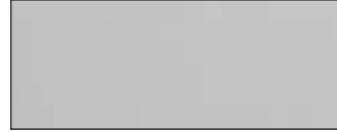

SILVER - LIGHT GREY

NB: Tutti i cristalli sono temperati
NB: All tempered glasses



art. 190/F (cm 40x27x60h)



art. 190/B (cm 71x35x50h)



art. 200/F (cm 78x25x55h)

LAMINATO

COLORI / COLOURS

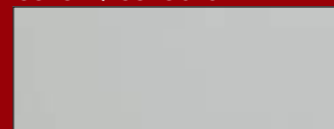

SILVER - LIGHT GREY



CILIEGIO - CHERRYWOOD



WENGÈ - WENGÈ



Esempio di bacheca con ripiani supplementari.
Example of hanging showcase with additional shelves.



art. 50/80 - (cm 49 x 15 x 81h)
schienale a specchio - mirror back glass



art. 80/50 - (cm 81 x 15 x 49h)
schienale a specchio - mirror back glass



art. 95/80 - (cm 95 x 15 x 81h)
schienale a specchio - mirror back glass



art. 2/PD
ganci per schienale dogato
hooks for slat wall



art. 60/45 - (cm 59 x 15 x 44h)
schienale a specchio - mirror back glass



art. 95/8L - (cm 95 x 15 x 81h)
schienale in lamiera forata per calamite o blister
perforated back panel for magnets or blister



Art. 50/B - cm 100 x 46 x 90h
Banco
Counter



Art. 50/TOP - cm 100x46
Top in cristallo satinato
Glazed glass top



Art. TOP/RE - cm 100x60
Top in cristallo satinato
Glazed glass top



Art. 40/TOP - cm 150x72
Top in cristallo satinato
Glazed glass top



Art. TOP/TT - cm 120x60
Top in cristallo satinato
Glazed glass top



Art. TOP/LT - cm 100x60
Top in cristallo satinato
Glazed glass top



art. 50/C
Cassettiera
Drawers



art. 50/MC
Mensola corta
Short shelf



art. 50/ML
Mensola lunga
Long shelf

COLORE / COLOUR



SILVER - LIGHT GREY

LAMINATO



art. 50/B (cm 100 x 46 x 90h) + 50/TOP + 50/C + 50/ML



art. 50/B (cm 100 x 46 x 90h) + 2 art. 50/ML

LAMINATO



art. 162/M (cm 50x46x90h)



art. 162/MG (cm 88x46x90h)

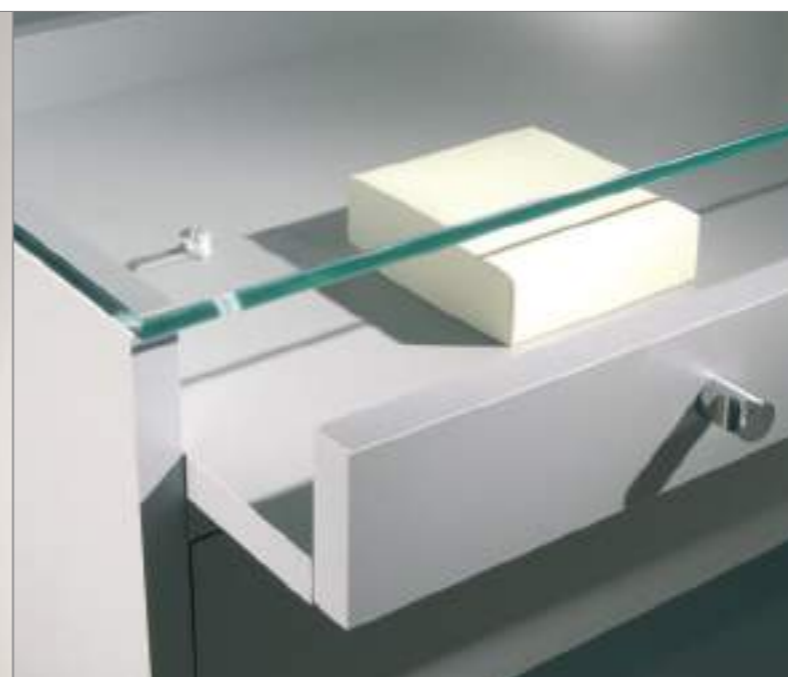

Esempio di art. 162/MG + art. 20/AS - Retro
Example of art. 162/MG + art. 20/AS - Back



Esempio di art. 162/M + art. 20/AS
Example of art. 162/M + art. 20/AS



Esempio di art. 162/MG + art. 20/AS - Davanti
Example of art. 162/MG + art. 20/AS - Front

LAMINATO



art. 92/AG (cm 73x73x90h)

Spessore Cristallo:
 Ante e schienali mm5
 Ripiani mm6
 Spalle e cielino mm8

Glass thickness:
 Doors and rear glasses mm5
 Shelves mm6
 Side and upper glasses mm8



art. 10/AC (cm 53x46x90h)



art. 20/AC (cm 73x46x90h)
 art. 20/AS (cm 93x46x90h)
 art. 20/AL (cm 93x60x90h)



art. 160/C1B (cm 126x46x90h)
 art. 160/C1C (cm 142x46x90h)
 art. 160/C1 (cm 182x46x90h)

art. 160/C1L (cm 142x60x90h)
 art. 160/1L (cm 182x60x90h)

LAMINATO



art. 180/E1S (cm 53x46x140h)



art. 60/BC (cm 73x46x140h)
art. 60/BS (cm 93x46x140h)



art. 160/C2C (cm 142x46x140h)
art. 160/C2 (cm 182x46x140h)

LAMINATO



art. 180/ES (cm 53x46x180h)



art. 130/CC (cm 73x46x180h)
art. 130/CS (cm 93x46x180h)



art. 182/AG (cm 73x73x180h)



art. 160/C3B (cm 126x46x180h)
art. 160/C3C (cm 142x46x180h)
art. 160/C3 (cm 182x46x180h)



art. 170/DS (cm 53x46x180h)

LAMINATO



art. 100/CS (cm 73x46x180h)
art. 100/BS (cm 93x46x180h)



art. 120/CS (cm 73x46x180h)
art. 120/BS (cm 93x46x180h)



art. 160/CMC (cm 142x46x180h)
art. 160/CM (cm 182x46x180h)



art. 201/FL (cm Ø74x187h)



art. 201/GL (cm Ø74x187h)



art. 181/ES (cm 53x46x188h)



art. 131/CC (cm 73x46x188h)
art. 131/CS (cm 93x46x188h)



art. 191/AG (cm 73x73x188h)

LAMINATO



art. 161/C3B (cm 126x46x188h)
art. 161/C3C (cm 142x46x188h)
art. 161/C3 (cm 182x46x188h)



art. 171/R (cm 56x43x188h)



art. 171/DS (cm 56x43x188h)



art. 121/CS (cm 73x46x188h)
art. 121/BS (cm 93x46x188h)



art. 101/CS (cm 73x46x188h)
art. 101/BS (cm 93x46x188h)

LAMINATO



art. 161/CMC (cm 142x46x188h)
art. 161/CM (cm 182x46x188h)

LAMINATO



Esempio di vetrina
con illuminazione laterale
*Example of showcase
with 3 side lights*



Esempio di vetrina
con ripiani
regolabili in
altezza o inclinati
*Example of
showcase
with adjustable
shelves*



art. 131/ca (cm 73x46x188h)
art. 131/sa (cm 93x46x188h)



Esempio di vetrine con schienale in metallo forato (vedi anche Laminato Light pag. 225 e Alldesign pag. 40)
Example of showcases with perforated back panel (see also Laminato Light page 225 and Alldesign page 40)



LAMINATO *light*



COM/LL1



COM/LL2





COM/LL3



COM/LL4

LAMINATO *light*



COM/LL5





COM/LL6
TUTTA LA COMPOSIZIONE
ALL THE COMPOSITION

h. 220

UNA NUOVA ALTEZZA, MAGGIORE CAPIENZA,
DIFFERENZA DI COSTO RIDOTTISSIMA.

h. 220

A NEW HEIGHT, MORE CAPACITY,
VERY LOW PRICE DIFFERENCE.

LAMINATO *light*

NB: LE VETRINE LAMINATO LIGHT SONO PRODOTTE DI SERIE CON CRISTALLO TEMPERATO.

NB: THE LAMINATO LIGHT STANDARD SHOWCASE ARE PROVIDED WITH TEMPERED GLASS.

COLORI / COLOURS

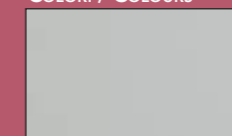

SILVER - LIGHT GREY



CILIEGIO - CHERRYWOOD



WENGÈ - WENGÈ

NB: ALTRI COLORI A RICHIESTA.

NB: OTHER COLOURS ON REQUEST.



Esempio di bacheca con ripiani supplementari.
Example of hanging showcase with additional shelves.



art. 50/80 - (cm 49 x 15 x 81h)
schienale a specchio - mirror back glass



art. 80/50 - (cm 81 x 15 x 49h)
schienale a specchio
mirror back glass



art. 95/80 - (cm 95 x 15 x 81h)
schienale a specchio
mirror back glass



art. 2/PD
ganci per schienale dogato
hooks for slat wall



art. 60/45 - (cm 59 x 15 x 44h)
schienale a specchio - mirror back glass



art. 95/8L - (cm 95 x 15 x 81h)
schienale in lamiera forata per calamite o blister
perforated back panel for magnets or blister

LAMINATO *light*

NB: TUTTI I BANCHI VETRINA HANNO DI SERIE
LE RUOTE CON FRENO.
NB: ALL STANDARD COUNTERS/SHOWCASES ARE
PROVIDED WITH LOCABLE CASTORS



art. 6/90B - (cm 62 x 40 x 90h)



art. 12/90B - (cm 119 x 40 x 90h)



art. 6/105B - (cm 62 x 40 x 105h)
bacheca aperta H15 cm.
open display case H15 cm.



art. 12/105B - (cm 119 x 40 x 105h)
bacheca aperta H15 cm.
open display case H15 cm.



art. 12/120B - (cm 119 x 40 x 120h)
bacheca chiusa H30 cm.
closed display case H30 cm.

LAMINATO *light*



art. 4/90 (cm 40x40x90h)



art. 6/90 (cm 60x40x90h)



art. 8/90 (cm 80x40x90h)



art. 12/90 (cm 117x40x90h)

LAMINATO *light*

COLORI / COLOURS



SILVER - LIGHT GREY



CILIEGIO - CHERRYWOOD



WENGÈ - WENGÈ



art. 16/90 (cm 157x40x90h)



art. 7/90 (cm 68x68x90h)



art. 8/90T (cm 80x60/40x90h)



art. 4/14 (cm 40x40x140h)



art. 6/14 (cm 60x40x140h)



art. 8/14 (cm 80x40x140h)

LAMINATO *light*



art. 12/14 (cm 117x40x140h)
art. 16/14 (cm 157x40x140h)



art. 4/14M (cm 40x40x130h)

NB: ALTEZZA MOBILI: DA TERRA CM 50H.
ALTEZZA ESTERNA CM 43H.
ALTEZZA INTERNA CM 37H.

NB: CABINET HEIGHT: FROM THE FLOOR CM 50H.
EXTERNAL HEIGHT CM 43H.
INTERNAL HEIGHT CM 37H.

LAMINATO *light*



art. 6/14M (cm 60x40x130h)



art. 8/14M (cm 80x40x130h)



art. 12/14M (cm 117x40x130h)
art. 16/14M (cm 157x40x130h)

LAMINATO *light*



art. 4/18 (cm 40x40x180h)



art. 6/18 (cm 60x40x180h)



art. 8/18 (cm 80x40x180h)



art. 12/18 (cm 117x40x180h)



art. 16/18 (cm 157x40x180h)



art. 7/18 (cm 68x68x180h)



art. 8/18T (cm 80x60/40x180h)

LAMINATO *light*



art. 4/18M (cm 40x40x180h)



art. 6/18M (cm 60x40x180h)



art. 8/18M (cm 80x40x180h)

LAMINATO *light*



art. 7/18M (cm 68x68x180h)



art. 12/18M (cm 117x40x180h)



art. 16/18M (cm 157x40x180h)

LAMINATO *light*

ESEMPIO DI ART. 8/18LB CON 4 RIPIANI
EXAMPLE OR ART. 8/18LB WITH 4 SHELVES



art. 4/18L (cm 40x40x181h)



art. 6/18L (cm 60x40x181h)



art. 8/18L (cm 80x40x181h)



art. 8/18LB (cm 80x40x181h)

LAMINATO *light*



art. 12/18L (cm 117x40x181h) 2 ante/ 2 doors
art. 16/18L (cm 157x40x181h) 4 ante/ 4 doors



art. 7/18L (cm 68x68x181h)



art. 8/18LT (cm 80x60/40x181h)

LAMINATO *light*



art. 4/18LM (cm 40x40x181h)



art. 6/18LM (cm 60x40x181h)



art. 8/18LM (cm 80x40x181h)

LAMINATO *light*



art. 7/18LM (cm 68x68x181h)



art. 12/18LM (cm 117x40x181h)



art. 16/18LM (cm 157x40x181h)



art. 4/22M (cm 40x40x220h)



art. 6/22M (cm 60x40x220h)



art. 8/22M (cm 80x40x220h)



art. 7/22M (cm 68x68x220h)



art. 12/22M (cm 117x40x220h)



art. 16/22M (cm 157x40x220h)

LAMINATO *light*



art. 4/18G (cm 40x40x187h)



art. 8/18G (cm 76x40x187h)



art. 8/18GE (cm Ø74x187h)



art. 4/18GM (cm 40x40x187h)



art. 8/18GM (cm 76x40x187h)

LAMINATO *light*



art. 4/14E (cm 40x40x140h)



art. 6/14E (cm 60x40x140h)



art. 8/14E (cm 80x40x140h)

COLORE / COLOUR



BIANCO - WHITE



NERO - BLACK

LAMINATO *light*



art. 4/18E (cm 40x40x180h)



art. 6/18E (cm 60x40x180h)



art. 8/18E (cm 80x40x180h)

COLORE / COLOUR



BIANCO - WHITE



NERO - BLACK

LAMINATO *light*



art. 4/18LE (cm 40x40x181h)



art. 6/18LE (cm 60x40x181h)



art. 8/18LE (cm 80x40x181h)

COLORE / COLOUR

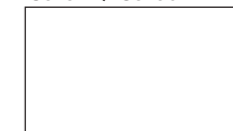

BIANCO - WHITE



NERO - BLACK



Il tempio

MUSEUM



MUSEUM



Il tempio









art. MU/120FT (cm 120x60x105h)



art. MU/120FTM (cm 120x60x105h)



art. MU/180FT (cm 180x80x105h)



art. MU/95FP (cm 95x25x80h)
Ripiani Regolabili - Adjustable shelves



art. MU/60F (cm 60x60x200h)
Ripiani Regolabili - Adjustable shelves



art. MU/60FM (cm 60x60x200h)
Ripiani Regolabili - Adjustable shelves



art. MU/60FC (cm 60x60x200h)
Ripiani Regolabili - Adjustable shelves



art. MU/120F (cm 120x60x200h)
Ripiani Regolabili - Adjustable shelves



art. MU/120FM (cm 120x60x200h)
Ripiani Regolabili - Adjustable shelves



art. MU/120FC (cm 120x60x200h)
Ripiani Regolabili - Adjustable shelves



Sistema di componibilità MUSEUM IRON
MUSEUM IRON modular system

Esempio di vetrina art. MU/120F COMPONENTIBILE
Example of showcase art. MU/120F MODULAR



Esempio di vetrina art. MU/120FC COMPONIBILE
Example of showcase art. MU/120FC MODULAR



Esempio di vetrina art. MU/120FT COMPONIBILE
Example of showcase art. MU/120FT MODULAR



art. MU/TB (cm 182x80x45h)
Teca montata con angolari
Display case mounted with corner pieces

art. MU/TBU (cm 182x80x45h)
Teca incollata con raggi UV
Display case mounted with UV rays

wood | MUSEUM

art. MU/180T (cm 182x80x105h)
Teca montata con angolari
Display case mounted with corner pieces

art. MU/180TU (cm 182x80x105h)
Teca incollata con raggi UV
Display case mounted with UV rays



art. MU/80 (cm 80x80x200h)
Ripiani Regolabili - Adjustable shelves



art. MU/120 (cm 120x60x200h)
Ripiani Regolabili - Adjustable shelves

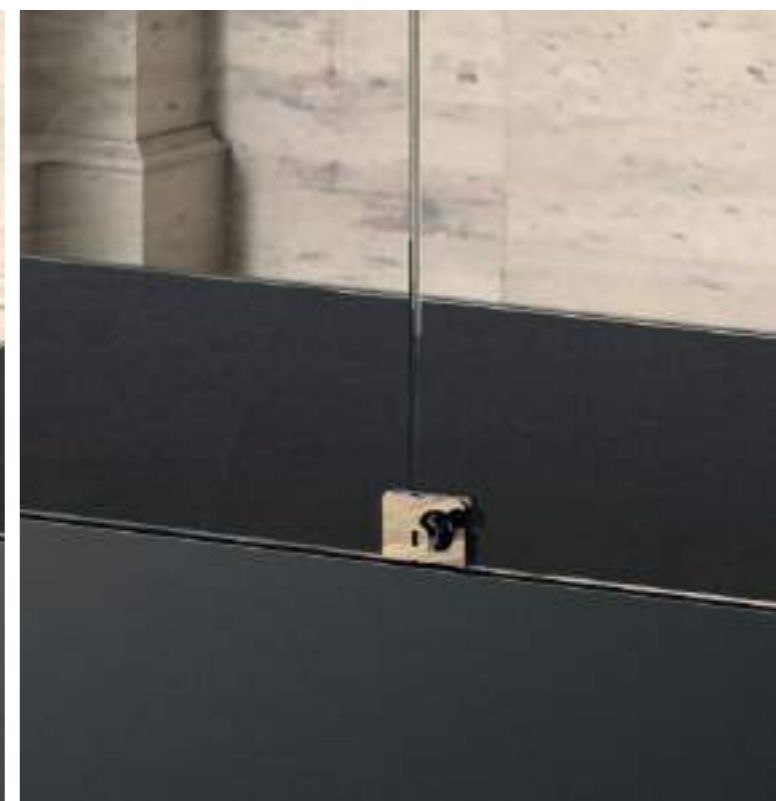

art. MU/160 (cm 160x60x200h)





 **QUADRATUM**





 **QUADRATUM**

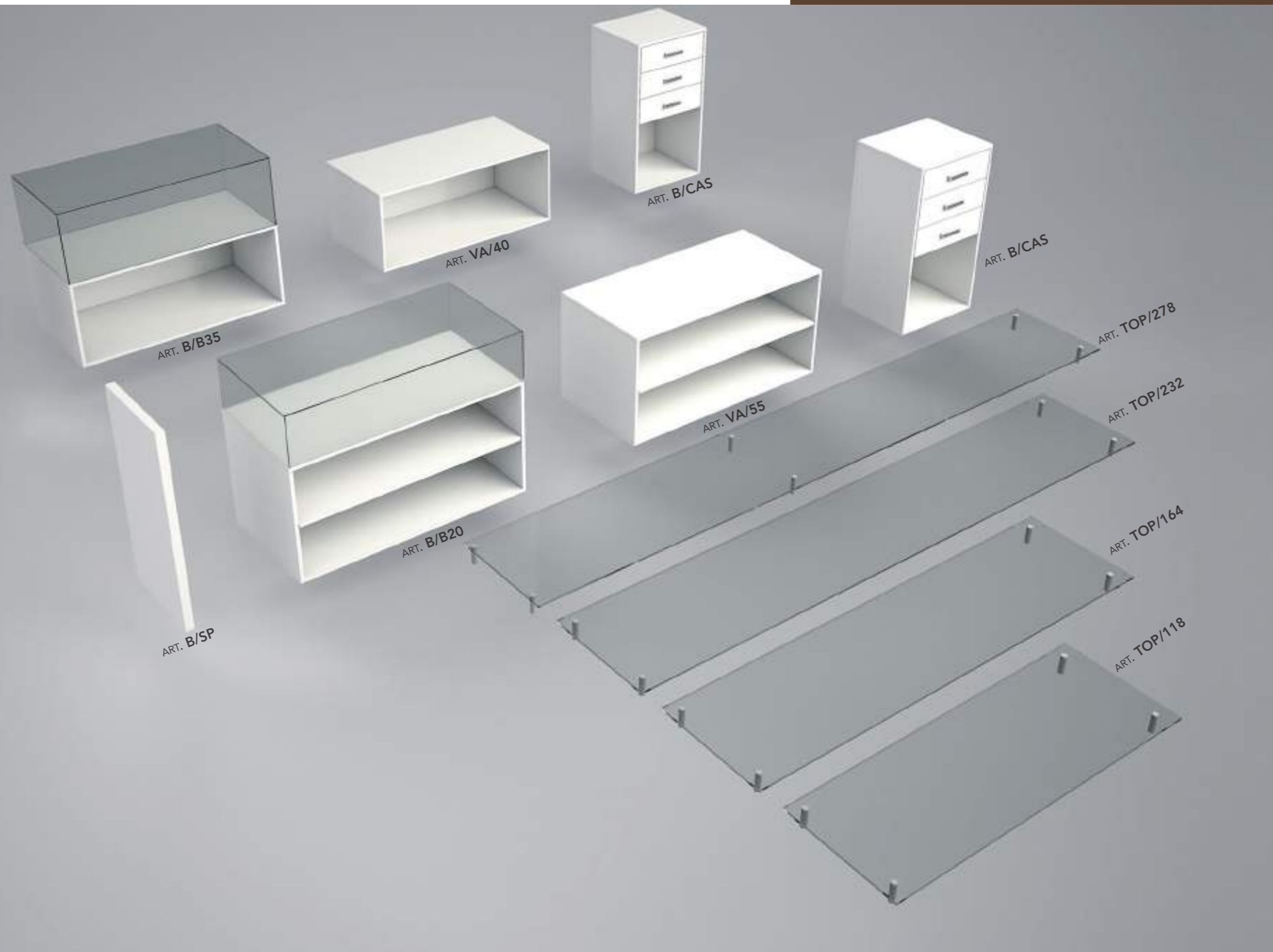

QUADRATUM

FINITURA LEGNO DI SERIE
STANDARD WOOD FINISH



BIANCO LUCIDO
GLOSSY WHITE

QUADRATUM

NB: TUTTI I CRISTALLI SONO TEMPERATI
NB: ALL GLASS ELEMENTS ARE TEMPERED

COM/QU1: CM 164 x 55 x 95H

N° 1 ART. **B/SP** - CM.43x90H SPALLA SPESSORE 40MM
N° 1 ART. **B/B35** - CM.110x55x450/35H (TOTALE 95H DA TERRA)
VANO CENTRALE CON TECA ALTA
N° 1 ART. **B/CAS** - CM.50x43x90H BANCO 3 CASSETTI

NB: POSSIBILITÀ DI ILLUMINAZIONE
CON FARETTI A LED E/O STRISCIA LED

COM/QU1: CM 164 x 55 x 95H

N°1 ART. **B/SP** - CM.43x90H SIDE 40MM THICK
N°1 ART. **B/B35** - CM.110x55x40/35H (TOTAL HEIGHT FROM FLOOR CM.95)
CENTRAL COMPARTMENT WITH HIGH GLASS CASE
N°1 ART. **B/CAS** - CM. 50x43x90H COUNTER WITH 3 DRAWERS

NB: OPTIONAL LED SPOTLIGHTS
AND/OR LED STRIPS



COM/QU2: cm 164 x 55 x 95H

N°1 ART. **B/CAS** - CM.50x43x90H BANCO 3 CASSETTI
N°1 ART. **B/B20** - CM.110x55x55/20H (TOTALE 95H DA TERRA)
VANO CENTRALE CON TECA BASSA
N°1 ART. **B/SP** - CM.43x90H SPALLA SPESSORE 40MM

COM/QU2: cm 164 x 55 x 95H

N° 1 ART. **B/CAS** - CM. 50x43x90H COUNTER WITH 3 DRAWERS
N° 1 ART. **B/B20** - CM. 110x55x55/20H (TOTAL HEIGHT FROM FLOOR CM.95)
CENTRAL COMPARTMENT WITH LOW GLASS CASE
N° 1 ART. **B/SP** - CM. 43x90H SIDE 40MM THICK



QUADRATUM

COM/QU3: cm 278 x 55 x 95H

N° 1 ART. **B/CAS** - CM.50x43x90H BANCO 3 CASSETTI
N° 2 ART. **VA/55** - CM.110x55x55H VANO A GIORNO ALTO
N° 2 ART. **B/SP** - CM.43x90H SPALLE SPESSORE 40MM
N° 1 ART. **TOP/278** - CM.55x278 SPESSORE 8MM CON DISTANZIALI
TOP IN CRISTALLO TEMPERATO

COM/QU3: cm 278 x 55 x 95H

N° 1 ART. **B/CAS** - CM. 50x43x90H COUNTER WITH 3 DRAWERS
N° 2 ART. **VA/55** - CM. 110x55x55H OPEN COMPARTMENT
N° 2 ART. **B/SP** - CM. 43x90H SIDES 40MM THICK
N° 1 ART. **TOP/278** - CM. 55x278 8MM THICK WITH SPACERS
TEMPERED TOP GLASS



NB: POSSIBILITÀ DI ILLUMINAZIONE CON FARETTI A LED E/O STRISCIA LED

NB: OPTIONAL LED SPOTLIGHTS AND/OR LED STRIPS



ART. **Q/50T** - CM.50x50x126H
 BANCO CHIUSO CON TECA IN CRISTALLO H26
 CLOSED COUNTER WITH GLASS CASE H26
 ART. **Q/50TP** - CM.50x50x126H
 BANCO CHIUSO CON CON TECA IN PLEXIGLASS H26
 CLOSED COUNTER WITH ACRYLIC CASE H26

ART. **Q/50AT** - CM.50x50x126H
 BANCO CON ANTA E RIPIANO INTERNO
 CON TECA IN CRISTALLO H26
 COUNTER WITH DOOR AND SHELF IN STORAGE AREA
 WITH GLASS CASE H26
 ART. **Q/50ATP** - CM.50x50x126H
 BANCO CON ANTA E RIPIANO INTERNO
 CON TECA IN PLEXIGLASS H26
 COUNTER WITH DOOR AND SHELF IN STORAGE AREA
 WITH ACRYLIC CASE H26



ART. **Q/50T6** - CM.50x50x160H
 BANCO CHIUSO CON TECA IN CRISTALLO H60
 CLOSED COUNTER WITH GLASS CASE H60

ART. **Q/50AT6** - CM.50x50x160H
 BANCO CON ANTA E RIPIANO INTERNO
 CON TECA IN CRISTALLO H60
 COUNTER WITH DOOR AND SHELF IN STORAGE AREA
 WITH GLASS CASE H60

QUADRATUM

- A - ART. **Q/50L** - CM.50x50x106H
BANCO CON ANTA E RIPIANO INTERNO,
CASSETTO CON FRONTALE IN CRISTALLO ESTRAIBILE,
CON ILLUMINAZIONE A LED, TECA IN CRISTALLO H25.
- A - ART. **Q/50L** - CM.50x50x106H
COUNTER WITH DOOR AND SHELF IN STORAGE AREA,
SLIDING DRAWER WITH GLASS FRONT, LED LIGHTING, GLASS CASE H25.
- B - ART. **Q/100L** - CM.100x50x106H
BANCO CON 2 ANTE E RIPIANO INTERNO,
CASSETTO CON FRONTALE IN CRISTALLO ESTRAIBILE,
CON ILLUMINAZIONE A LED, TECA IN CRISTALLO H25
- B - ART. **Q/100L** - CM.100x50x106H
COUNTER WITH 2 DOORS AND SHELF IN STORAGE AREA,
SLIDING DRAWER WITH GLASS FRONT, LED LIGHTING, GLASS CASE H25.



A

B



NB: POSSIBILITÀ
DI ILLUMINAZIONE
CON STRISCIA LED.
NB: OPTIONAL LED
STRIPS LIGHTING.

ART. **Q/80** - CM.80x40x196H
VETRINA IN CRISTALLO TEMPERATO, 2 ANTE
8 FARETTI LED LATERALI 2 FARETTI LED NEL TOP,
1 CASSETTO CON SERRATURA.

ART. **Q/80** - CM.80x40x196H
TEMPERED GLASS SHOWCASE, 2 DOORS,
8 LED SIDE LIGHTS AND 2 LED CANOPY LIGHTS,
1 LOCKABLE DRAWER.



ART. **Q/120** - CM.120x40x196H
VETRINA IN CRISTALLO TEMPERATO, 2 ANTE
8 FARETTI LED LATERALI 2 FARETTI LED NEL TOP,
1 CASSETTO CON SERRATURA.

ART. **Q/120** - CM.120x40x196H
TEMPERED GLASS SHOWCASE, 2 DOORS,
8 LED SIDE LIGHTS AND 2 LED CANOPY LIGHTS,
1 LOCKABLE DRAWER.



NB: POSSIBILITÀ DI ILLUMINAZIONE CON STRISCIA LED SUL LATO DIETRO.
NB: OPTIONAL LED STRIPS LIGHTING ON BACK SIDE.

A - ART. **Q/45** - CM.45x45x190H
 VETRINA IN CRISTALLO TEMPERATO 1 ANTA,
 5 FARETTI LED LATERALI,
 4 RIPIANI REGOLABILI IN ALTEZZA.

A - ART. **Q/45** - CM.45x45x190H
 SHOWCASE WITH 1 TEMPERED GLASS DOOR,
 5 LED SIDE LIGHTS,
 4 HEIGHT-ADJUSTABLE SHELVES.

B - ART. **Q/45M** - CM.45x45x190H
 VETRINA IN CRISTALLO TEMPERATO 1 ANTA,
 4 FARETTI LED LATERALI,
 3 RIPIANI REGOLABILI IN ALTEZZA,
 MOBILE CON 1 ANTA LEGNO E SERRATURA.

B - ART. **Q/45M** - CM.45x45x190H
 SHOWCASE WITH 1 TEMPERED GLASS DOOR,
 4 LED SIDE LIGHTS,
 3 HEIGHT-ADJUSTABLE SHELVES,
 1 WOODEN LOCKABLE DOOR.



ART. **Q/85** - CM.85x45x190H
 VETRINA IN CRISTALLO TEMPERATO, 2 ANTE,
 10 FARETTI LED LATERALI,
 4 RIPIANI REGOLABILI IN ALTEZZA.

ART. **Q/85** - CM.85x45x190H
 TEMPERED GLASS SHOWCASE, 2 DOORS,
 10 LED SIDE LIGHTS,
 4 HEIGHT-ADJUSTABLE SHELVES.



NB: POSSIBILITÀ
DI ILLUMINAZIONE
CON STRISCIA LED
SUL LATO DIETRO.
NB: OPTIONAL LED
STRIPS LIGHTING ON
BACK SIDE.

ART. **Q/85M** - CM.85x45x190H
VETRINA IN CRISTALLO TEMPERATO, 2 ANTE,
8 FARETTI LED LATERALI,
4 RIPIANI REGOLABILI IN ALTEZZA.

ART. **Q/85M** - CM.85x45x190H
TEMPERED GLASS SHOWCASE, 2 DOORS,
8 LED SIDE LIGHTS,
4 HEIGHT-ADJUSTABLE SHELVES.



B - ART. **VE/60C** - CM.60x40x210H
VETRINA IN CRISTALLO TEMPERATO, 1 ANTA
1 CASSETTO, 2 FARETTI LED,

B - ART. **VE/60C** - CM.60x40x210H
TEMPERED GLASS SHOWCASE, 1 DOOR
1 DRAWER, 2 LED LIGHTS.

A - ART. **VE/60** - CM.60x40x210H
VETRINA IN CRISTALLO TEMPERATO, 1 ANTA,
2 FARETTI LED,

A - ART. **VE/60** - CM.60x40x210H
TEMPERED GLASS SHOWCASE, 1 DOOR
2 LED LIGHTS.
- CM.60x40x210H



ART. **VE/120** - CM.120x40x210H
 VETRINA IN CRISTALLO TEMPERATO, 2 ANTE,
 3 FARETTI LED

ART. **VE/120** - CM.120x40x210H
 TEMPERED GLASS SHOWCASE, 2 DOORS
 3 LED LIGHTS.



ART. **VE/120C** - CM.120x40x210H
 VETRINA IN CRISTALLO TEMPERATO, 2 ANTE
 1 CASSETTO, 3 FARETTI LED

ART. **VE/120C** - CM.120x40x210H
 TEMPERED GLASS SHOWCASE, 2 DOORS
 1 DRAWER, 3 LED LIGHTS.

QUADRATUM

FINITURE LEGNO DI SERIE STANDARD WOOD FINISHES



BIANCO LUCIDO
GLOSSY WHITE

FINITURE LEGNO OPTIONAL OPTIONAL WOOD FINISHES

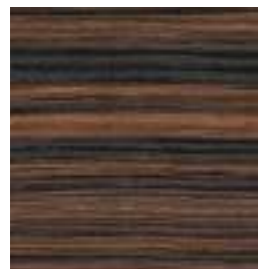

PALISSANDRO ★
ROSEWOOD



ACERO ★
MAPLE

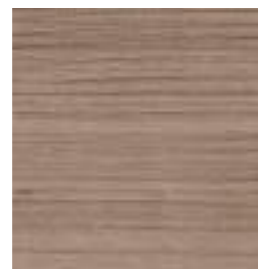

ROVERE ★
OAK



SILVER ★
SILVER



OSB ★
OSB

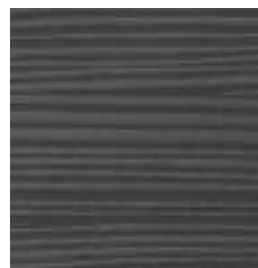

ANTRACITE ★
CHARCOAL



BETON ★
BETON



VINTAGE ★
VINTAGE

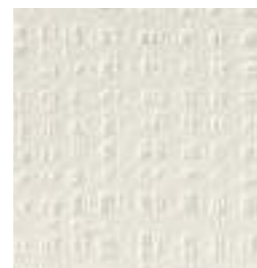

MADREPERLA ★
MOTHER-OF-PEARL



NERO OPACO
MATT BLACK

NB: ★ VENATURE LEGNO IN RILIEVO
NB: ★ EMBOSSED WOOD GRAINS





frame
QUADRATUM



COM/QF17

frame
QUADRATUM



BANCO componibile
MODULAR COUNTER

QUADRATUM frame

NB: TUTTI I CRISTALLI SONO TEMPERATI
NB: ALL GLASS ELEMENTS ARE TEMPERED



NB: CASSETTO ESTRAIBILE CON SERRATURA
E FRONTALE IN CRISTALLO
ILLUMINAZIONE STRISCIA LED 4000° KELVIN
NB: LOCKABLE SLIDING DRAWER
WITH GLASS FRONT
4000° KELVIN LED STRIP LIGHT



ART. **QF/5BS** - CM.50x53x100H
BANCO DI SERVIZIO CON ANTA

ART. **QF/5BS** - CM.50x53x100H
SERVICE COUNTER WITH DOOR

ART. **QF/5B** - CM.50x53x100H - TECA H. CM. 30
BANCO CON ANTA, SERRATURA, CASSETTO ESTRAIBILE
CON FRONTALE IN CRISTALLO E ILLUMINAZIONE CON STRISCIA LED

ART. **QF/5B** - CM.50x53x100H - GLASS CASE H. CM.30
COUNTER WITH LOCKABLE DOOR, SLIDING DRAWER
WITH GLASS FRONT AND LED STRIP LIGHTING



COLORE STRUTTURA
STRUCTURE COLOUR

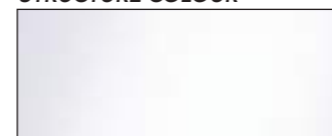

BIANCO LUCIDO - GLOSSY WHITE

COLORI FASCIA DECORATIVA
DECORATIVE PANEL COLOURS



BIANCO LUCIDO - GLOSSY WHITE



ACERO - MAPLE



ART. **QF/5P** - CM.50x53x70H
MODULO PORTA

ART. **QF/5P** - CM.50x53x70H
DOOR MODULE



ART. **QF/5BC** - CM.50x53x120H
BANCO CASSA CON CASSETTO

ART. **QF/5BC** - CM.50x53x120H
CASH COUNTER WITH DRAWER



ESEMPIO DI ART. QF/5T CON ILLUMINAZIONE A LED
EXAMPLE OF ART. QF/5T WITH LED LIGHT

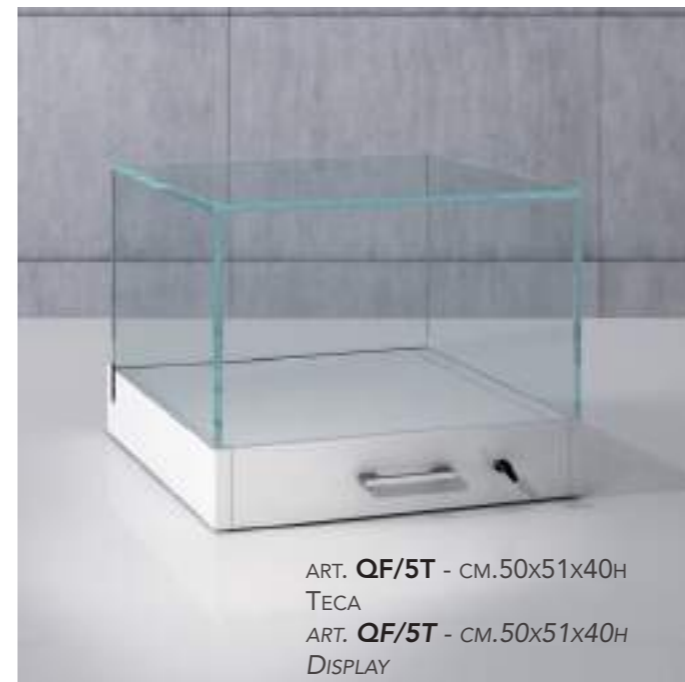

ART. **QF/5T** - CM.50x51x40H
TECA
ART. **QF/5T** - CM.50x51x40H
DISPLAY

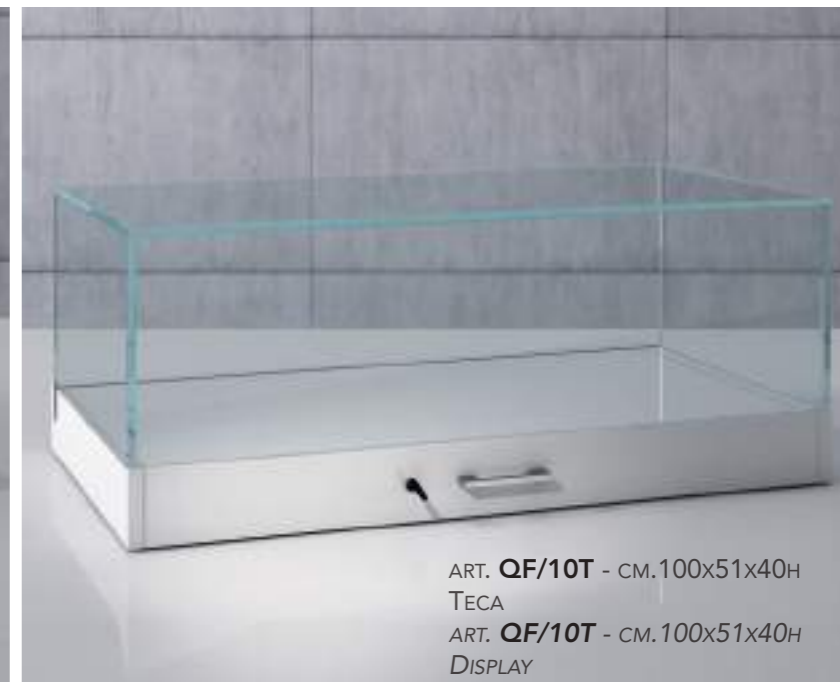

ART. **QF/10T** - CM.100x51x40H
TECA
ART. **QF/10T** - CM.100x51x40H
DISPLAY

ART. **QF/10B** - CM.100x53x100H
TECA H. CM. 30
BANCO CON ANTE E CASSETTO ESTRAIBILE,
FRONTALE IN CRISTALLO E ILLUMINAZIONE CON STRISCIA LED

ART. **QF/10B** - CM.100x53x100H
GLASS CASE H. CM.30
COUNTER WITH DOORS AND SLIDING DRAWER
WITH GLASS FRONTS AND LED STRIP LIGHTING



ART. **QF/10BS** - CM.100x53x100H
BANCO DI SERVIZIO CON ANTE

ART. **QF/10BS** - CM.100x53x100H
SERVICE COUNTER WITH DOORS



ART. **QF/10BC** - CM.100x53x120H
BANCO CASSA CON CASSETTO

ART. **QF/10BC** - CM.100x53x120H
CASH COUNTER WITH DRAWER



ART. **QF/10BA** - CM.100x100x100H - TECA H. CM. 30
BANCO ANGOLARE CON ANTE, SERRATURE, FRONTALI IN CRISTALLO
E ILLUMINAZIONE CON STRISCIA LED

ART. **QF/10BA** - CM.100x100x100H - GLASS CASE H. CM.30
CORNER COUNTER WITH LOCKABLE DOORS, GLASS FRONTS
AND LED STRIP LIGHTING



← ART. **QF/RE** - CM.55x55x150H -
TECA H. CM. 85
RACCORDO ANGOLARE ESTERNO
PER BANCHI
4 STRISCE LED SOTTO AL TOP

ART. **QF/RE** - CM.55x55x150H -
GLASS CASE H. CM.85
OUTER CORNER CONNECTOR FOR
COUNTERS
4 LED STRIPS UNDER THE TOP



ESEMPIO DI COMPOSIZIONE - EXAMPLE OF COMPOSITIONS



ART. **QF/SC** - CM. 105x42x210H.
ILLUMINAZIONE CON STRISCIA LED / LED STRIP LIGHTING



ART. **QF/CC** - CM. 98x42x210H.
ILLUMINAZIONE CON STRISCIA LED / LED STRIP LIGHTING



ART. **QF/S** - CM. 105x42x210H.
ILLUMINAZIONE CON STRISCIA LED / LED STRIP LIGHTING



ART. **QF/C** - CM. 98x42x210H.
ILLUMINAZIONE CON STRISCIA LED / LED STRIP LIGHTING



ART. **QF/A** - CM. 100x100x42x210H.
ILLUMINAZIONE CON STRISCIA LED / LED STRIP LIGHTING



ART. **QF/AA** - CM. 100x100x42x210H.
ILLUMINAZIONE CON STRISCIA LED / LED STRIP LIGHTING



ART. **QF/SA** - CM.105x42x210H.
ILLUMINAZIONE CON STRISCIA LED / LED STRIP LIGHTING



ART. **QF/CA** - CM.98x42x210H.
ILLUMINAZIONE CON STRISCIA LED / LED STRIP LIGHTING



ESEMPIO DI VETRINA **QF/SA**
CON VETRI SCORREVOLI
EXAMPLE OF **QF/SA** SHOWCASE
WITH SLIDING GLASS



ART. **QF/R**
RIPIANI IN LEGNO
CON STRISCE LED
ART. **QF/R**
WOODEN SHELVES
WITH LED STRIPS



COLORE STRUTTURA
STRUCTURE COLOUR



BIANCO - WHITE

COLORI FASCIA DECORATIVA
DECORATIVE PANEL COLOURS



BIANCO LUCIDO - GLOSSY WHITE



ACERO - MAPLE

COM/QF1: cm 150 x 53 x 100/120H

N°1 ART. **QF/10B** - cm.100x53x100H

BANCO CON ANTE E CASSETTO ESTRAIBILE

N°1 ART. **QF/5BC** - cm.50x53x120H

BANCO CASSA CON CASSETTO

COM/QF1: cm 150 x 53 x 100/120H

N°1 ART. **QF/10B** - cm.100x53x100H

COUNTER WITH DOORS AND SLIDING DRAWER

N°1 ART. **QF/5BC** - cm.50x53x120H

CASH COUNTER WITH DRAWER



COM/QF2: cm 200 x 53 x 100/120H

N°2 ART. **QF/5B** - cm.50x53x100H

BANCO CON ANTA E CASSETTO ESTRAIBILE

N°1 ART. **QF/10BC** - cm.100x53x120H

BANCO CASSA CON CASSETTO

COM/QF2: cm 200 x 53 x 100/120H

N°2 ART. **QF/5B** - cm.50x53x100H

COUNTER WITH DOOR AND SLIDING DRAWER

N°1 ART. **QF/10BC** - cm.100x53x120H

CASH COUNTER WITH DRAWER



COM/QF3: cm 200 x 53 x 100/120H

- N°1 ART. **QF/10B** - CM.100x53x100H
BANCO CON ANTE E CASSETTO ESTRAIBILE
- N°1 ART. **QF/5BC** - CM.50x53x120H
BANCO CASSA CON CASSETTO
- N°1 ART. **QF/5B** - CM.50x53x100H
BANCO CON ANTA E CASSETTO ESTRAIBILE

COM/QF3 : cm 200 x 53 x 100/120H

- N°1 ART. **QF/10B** - CM.100x53x100H
COUNTER WITH DOORS AND SLIDING DRAWER
- N°1 ART. **QF/5BC** - CM.50x53x120H
CASH COUNTER WITH DRAWER
- N°1 ART. **QF/5B** - CM.50x53x100H
COUNTER WITH DOORS AND SLIDING DRAWER

COM/QF4: cm 250 x 53 x 100/120H:

- N°2 ART. **QF/5B** - CM.50x53x100H
BANCO CON ANTA E CASSETTO ESTRAIBILE
- N°1 ART. **QF/5BC** - CM.50x53x120H
BANCO CASSA CON CASSETTO
- N°1 ART. **QF/10BS** - CM.100x53x100H
BANCO DI SERVIZIO CON ANTE

COM/QF4: cm 250 x 53 x 100/120H:

- N°2 ART. **QF/5B** - CM.50x53x100H
COUNTER WITH DOORS AND SLIDING DRAWER
- N°1 ART. **QF/5BC** - CM.50x53x120H
CASH COUNTER WITH DRAWER
- N°1 ART. **QF/10BS** - CM.100x53x100H
SERVICE COUNTER WITH DOORS



QUADRATUM ^{frame}

COM/QF5: cm 200 x 250 x 100/120H

- N°1 ART. **QF/5B** - CM.50x53x100H
BANCO CON ANTA E CASSETTO ESTRAIBILE
- N°1 ART. **QF/5P** - CM.50x53x70H
MODULO PORTA
- N°1 ART. **QF/10BA** - CM.100x100x100H
BANCO ANGOLARE CON ANTE
- N°1 ART. **QF/5BC** - CM.50x53x120H
BANCO CASSA CON CASSETTO
- N°1 ART. **QF/10B** - CM.100x53x100H
BANCO CON ANTE E CASSETTO ESTRAIBILE
- N°1 ART. **QF/10BS** - CM.100x53x100H
BANCO DI SERVIZIO CON ANTE

COM/QF5: cm 200 x 250 x 100/120H

- N°1 ART. **QF/5B** - CM.50x53x100H
COUNTER WITH DOOR AND SLIDING DRAWER
- N°1 ART. **QF/5P** - CM.50x53x70H
DOOR MODULE
- N°1 ART. **QF/10BA** - CM.100x100x100H
CORNER COUNTER WITH DOORS
- N°1 ART. **QF/5BC** - CM.50x53x120H
CASH COUNTER WITH DRAWER
- N°1 ART. **QF/10B** - CM.100x53x100H
COUNTER WITH DOORS AND SLIDING DRAWER
- N°1 ART. **QF/10BS** - CM.100x53x100H
SERVICE COUNTER WITH DOORS



COM/QF5

COM/QF6 : cm 300 x 200 x 100/120H

N°2 ART. **QF/10B** - cm. 100x53x100H
BANCO CON ANTE E CASSETTO ESTRAIBILE

N°1 ART. **QF/10BC** - cm. 100x53x120H
BANCO CASSA CON CASSETTO

N°1 ART. **QF/10BA** - cm. 100x100x100H
BANCO ANGOLARE CON ANTE

COM/QF6: cm 300 x 200 x 100/120H

N°2 ART. **QF/10B** - cm. 100x53x100H
COUNTER WITH DOORS AND SLIDING DRAWER

N°1 ART. **QF/10BC** - cm. 100x53x120H
CASH COUNTER WITH DRAWER

N°1 ART. **QF/10BA** - cm. 100x100x100H
CORNER COUNTER WITH DOORS

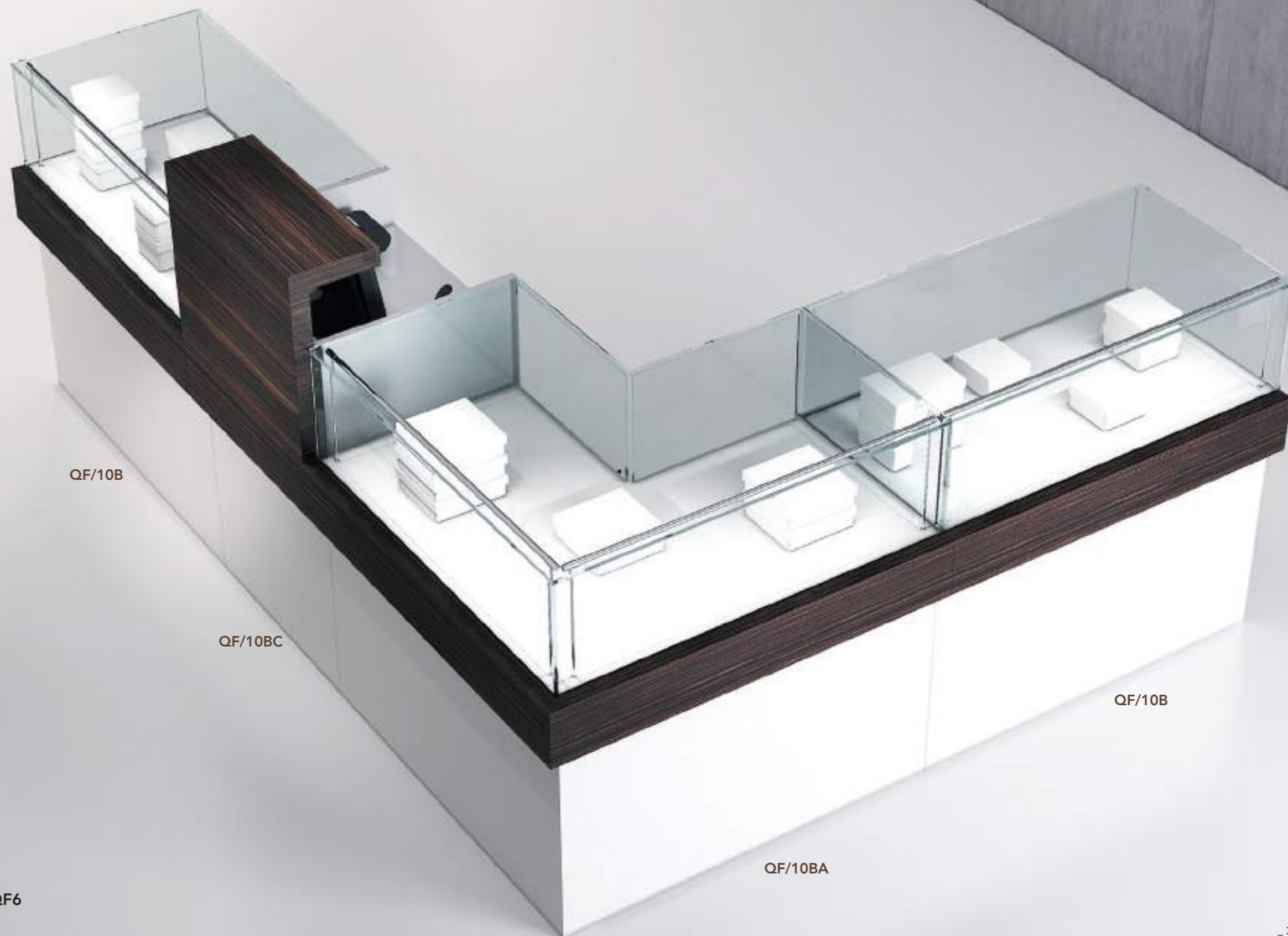

QF/10B

QF/10BC

QF/10B

QF/10BA

COM/QF6

COM/QF7:
 CM 250 x 250 x 70/100/120H
 N°2 ART. **QF/10BA** - CM.100x100x100H
 BANCO ANGOLARE CON ANTE
 N°1 ART. **QF/5BC** - CM.50x53x120H
 BANCO CASSA CON CASSETTO
 N°2 ART. **QF/10B** - CM.100x53x100H
 BANCO CON ANTE E CASSETTO ESTRAIBILE
 N°1 ART. **QF/5B** - CM.50x53x100H
 BANCO CON ANTA E CASSETTO ESTRAIBILE
 N°1 ART. **QF/5P** - CM.50x53x70H
 MODULO PORTA

COM/QF7:
 CM 250 x 250 x 70/100/120H
 N°2 ART. **QF/10BA** - CM.100x100x100H
 CORNER COUNTER WITH DOORS
 N°1 ART. **QF/5BC** - CM.50x53x120H
 CASH COUNTER WITH DRAWER
 N°2 ART. **QF/10B** - CM.100x53x100H
 COUNTER WITH DOORS AND SLIDING DRAWER
 N°1 ART. **QF/5B** - CM.50x53x100H
 COUNTER WITH DOOR AND SLIDING DRAWER
 N°1 ART. **QF/5P** - CM.50x53x70H
 DOOR MODULE

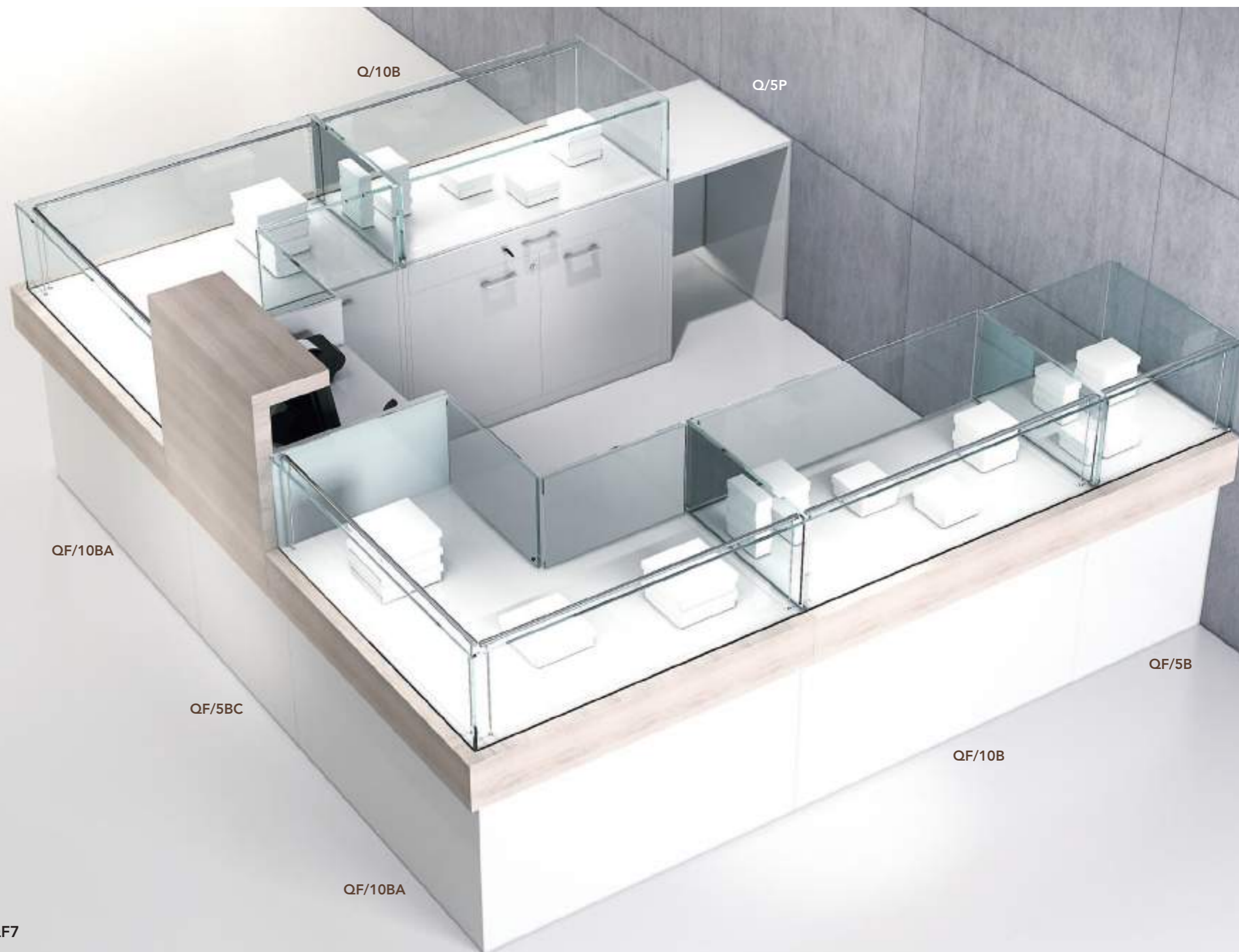

COM/QF7

COM/QF8:

CM 250 x 350 x 100/120H

N°4 ART. **QF/10BA** - CM.100x100x100H

BANCO ANGOLARE CON ANTE

N°1 ART. **QF/5B** - CM.50x53x100H

BANCO CON ANTA E CASSETTO ESTRAIBILE

N°1 ART. **QF/10BS** - CM.100x53x100H

BANCO DI SERVIZIO CON ANTE

N°2 ART. **QF/5BC** - CM.50x53x120H

BANCO CASSA CON CASSETTO

N°1 ART. **QF/10B** - CM.100x53x100H

BANCO CON ANTE E CASSETTO ESTRAIBILE

N°1 ART. **QF/5P** - CM.50x53x70H

MODULO PORTA

COM/QF8:

CM 250 x 350 x 100/120H

N°4 ART. **QF/10BA** - CM.100x100x100H

CORNER COUNTER WITH DOORS

N°1 ART. **QF/5B** - CM.50x53x100H

COUNTER WITH DOOR AND SLIDING DRAWER

N°1 ART. **QF/10BS** - CM.100x53x100H

SERVICE COUNTER WITH DOORS

N°2 ART. **QF/5BC** - CM.50x53x120H

CASH COUNTER WITH DRAWER

N°1 ART. **QF/10B** - CM.100x53x100H

COUNTER WITH DOORS AND SLIDING DRAWER

N°1 ART. **QF/5P** - CM.50x53x70H

DOOR MODULE

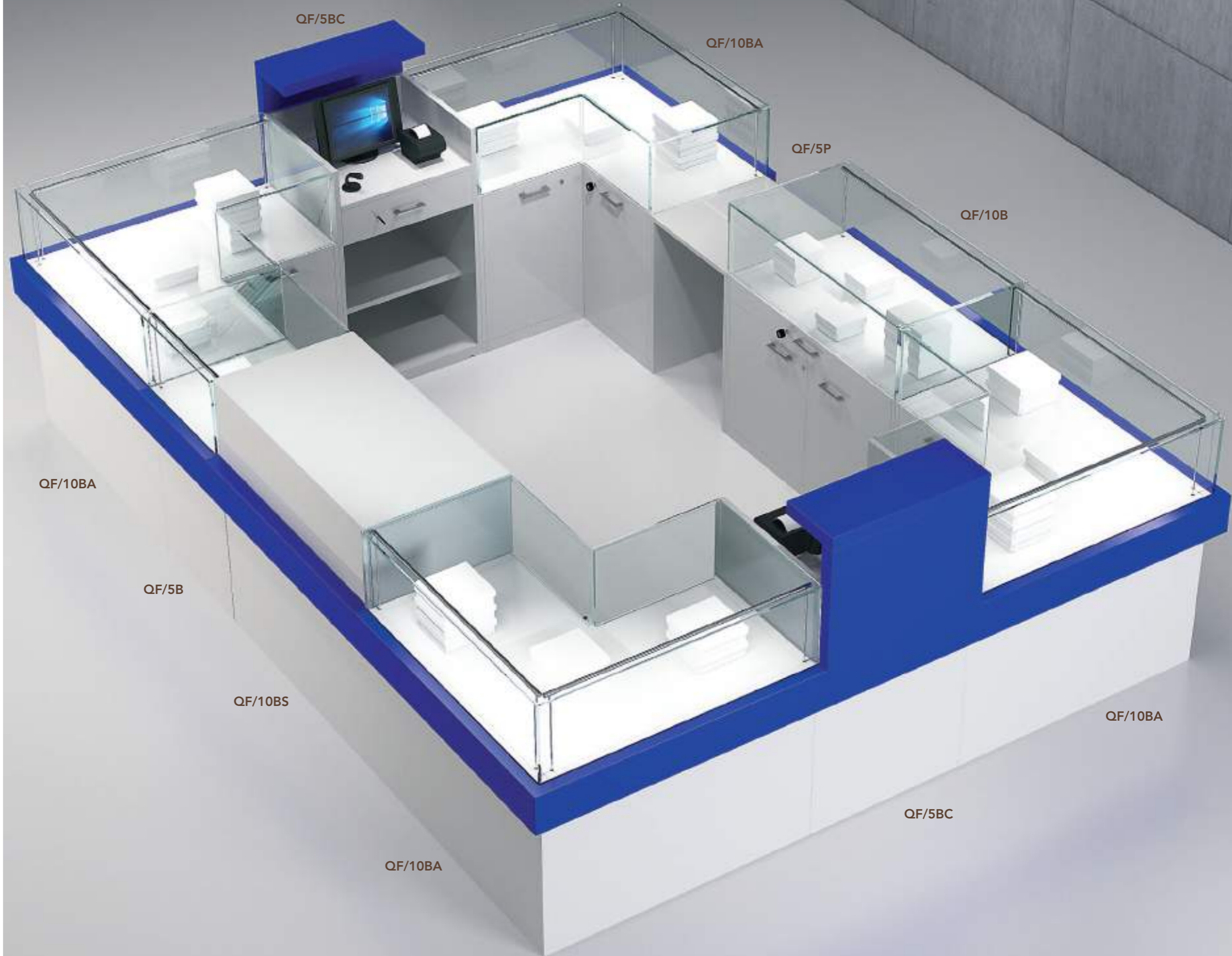

COM/QF8



QF/10BA

QF/5B

QF/10BC

COM/QF9

QF/10BA

QF/10B

QF/5P

QF/10BS

QF/10BS

QF/10BA

QF/5B

QF/10B

QF/10BA

QF/10BS

QF/5BS

COM/QF9: cm 350 x 350 x 100/120H

N°4 ART. **QF/10BA** - cm.100x100x100H

BANCO ANGOLARE CON ANTE

N°2 ART. **QF/5B** - cm.50x53x100H

BANCO CON ANTA E CASSETTO ESTRAIBILE

N°1 ART. **QF/10BC** - cm.100x53x120H

BANCO CASSA CON CASSETTO

N°1 ART. **QF/5BS** - cm.50x53x100H

BANCO DI SERVIZIO CON ANTA

N°3 ART. **QF/10BS** - cm.100x53x100H

BANCO DI SERVIZIO CON ANTE

N°2 ART. **QF/10B** - cm.100x53x100H

BANCO CON ANTE E CASSETTO ESTRAIBILE

N°1 ART. **QF/5P** - cm.50x53x70H

MODULO PORTA

COM/QF9: cm 350 x 350 x 100/120H

N°4 ART. **QF/10BA** - cm.100x100x100H

CORNER COUNTER WITH DOORS

N°2 ART. **QF/5B** - cm.50x53x100H

COUNTER WITH DOOR AND SLIDING DRAWER

N°1 ART. **QF/10BC** - cm.100x53x120H

CASH COUNTER WITH DRAWER

N°1 ART. **QF/5BS** - cm.50x53x100H

SERVICE COUNTER WITH DOOR

N°3 ART. **QF/10BS** - cm.100x53x100H

SERVICE COUNTER WITH DOORS

N°2 ART. **QF/10B** - cm.100x53x100H

COUNTER WITH DOORS AND SLIDING DRAWER

N°1 ART. **QF/5P** - cm.50x53x70H

DOOR MODULE



COM/QF10



COM/QF11



COM/QF12





COM/QF14



COM/QF15



COM/QF16





TopLine 3



TopLine 3





TopLine 





TopLine 3

TopLine

ESEMPIO DI ART. 203/B
COLORE ROVERE CON RUOTE
EXAMPLE OF ART. 203/B
IN OAK FINISH WITH CASTORS



COLORI STANDARD / STANDARD COLOURS



BIANCO LUCIDO - GLOSSY WHITE

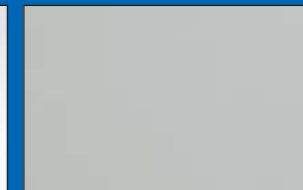

SILVER - LIGHT GREY

LE VETRINE TOPLINE SONO IN CRISTALLO TEMPERATO. LUCI A LED DI SERIE.

THE SHOWCASES OF THE TOPLINE COLLECTION ARE MADE OF TEMPERED GLASS. LED LIGHTS AS STANDARD.

ALTRI COLORI A RICHIESTA

OTHER COLOURS ON REQUEST



art. 203/B (cm Ø72x93h)



art. 203/OB (cm 96x56x93h)



ESEMPIO ART. 203/MB IN COLORE NERO ART. 3/MB
EXAMPLE OF ART. 203/MB IN BLACK COLOUR ART. 3/MB



ESEMPIO DI ART. 203/MB POSIZIONATO A PARETE
EXAMPLE OF ART. 203/MB AGAINST THE WALL



art. 203/AN (cm 58x58x190h)
NB: 2 SERRATURE / 2 LOKS



art. 203/T (cm 48x48x190h)



art. 203/ML (cm Ø56x190h)



ESEMPIO ART. 203/ML IN COLORE ROSSO ART. 3/ML
EXAMPLE OF ART. 203/ML IN RED COLOUR ART. 3/ML



ESEMPIO ART. 203/OP IN COLORE ROSSO ART. 3/OP
EXAMPLE OF ART. 203/OP IN RED COLOUR ART. 3/OP

art. 203/RF (cm Ø56x190h)
art. 203/R7 (cm Ø71x190h)

art. 203/OP (cm 64x44x190h)



art. 203/M (cm 112x38x190h)



art. 203/OG (cm 96x56x190h)



ESEMPIO ART. 203/OG IN COLORE AZZURRO ART. 3/OG
EXAMPLE OF ART. 203/OG IN LIGHT BLUE COLOUR ART. 3/OG



TopLine 9



TopLine 9



TopLine 9



TopLine 9

LE VETRINE TOPLINE SONO IN CRISTALLO TEMPERATO. LUCI A LED DI SERIE.

THE SHOWCASES OF THE TOPLINE COLLECTION ARE MADE OF TEMPERED GLASS. LED LIGHTS AS STANDARD.

STANDARD COLOUR

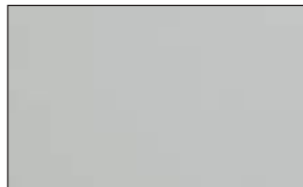

SILVER - LIGHT GREY

ALTRI COLORI A RICHIESTA
OTHER COLOURS ON REQUEST



ESEMPIO DI ART. 209/MB POSIZIONATO A PARETE
EXAMPLE OF ART. 209/MB AGAINST THE WALL



DETTAGLIO DEL PIANO
COUNTER TOP DETAIL



TopLine 9



art. 209/AN (cm 58x58x190h)

NB: 2 SERRATURE / 2 LOKS

» 388 _



art. 209/ML (cm Ø57x190h)



art. 209/RF (cm Ø56x190h)

art. 209/R7 (cm Ø71x190h)



art. 209/RG (cm Ø71x190h)

_ 389 «

TopLine 9



art. 209/OP (cm 64x44x190h)



art. 209/OG (cm 97x56x190h)



art. 209/M (cm 112x38x190h)



TMETAL



T METAL

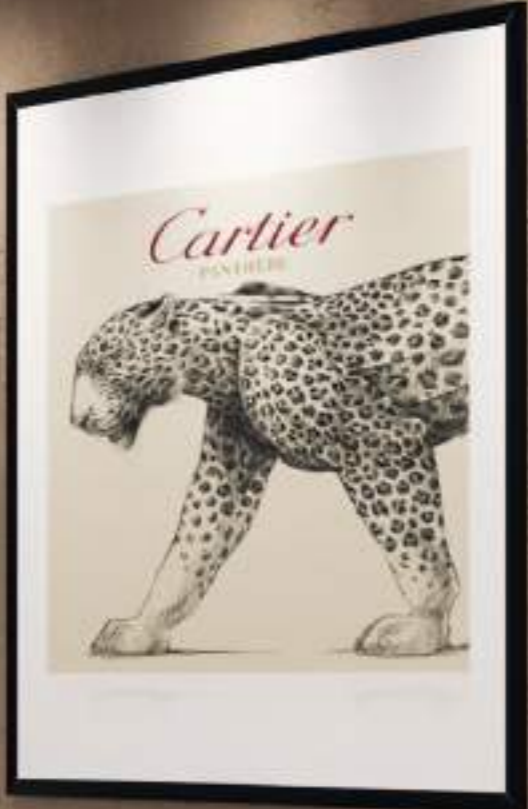



NEW YORK

TOKYO

LONDRA





T METAL







T METAL



art. TM/95P (cm 95x25x80h)



art. TM/95T (cm 95x45x95h)



art. TM/45T (cm 45x45x95h)



art. TM/150T (cm 150x45x95h)



art. TM/45B (cm 45x45x95h)



art. TM/95B (cm 95x45x95h)



art. TM/75B (cm 75x45x95h)



art. TM/95BM (cm 95x45x95h)



art. TM/45V (cm 45x45x190h)
Ripiani Regolabili - Adjustable shelves



art. TM/75V (cm 75x45x190h)
Ripiani Regolabili - Adjustable shelves



art. TM/95V (cm 95x45x190h)
Ripiani Regolabili - Adjustable shelves

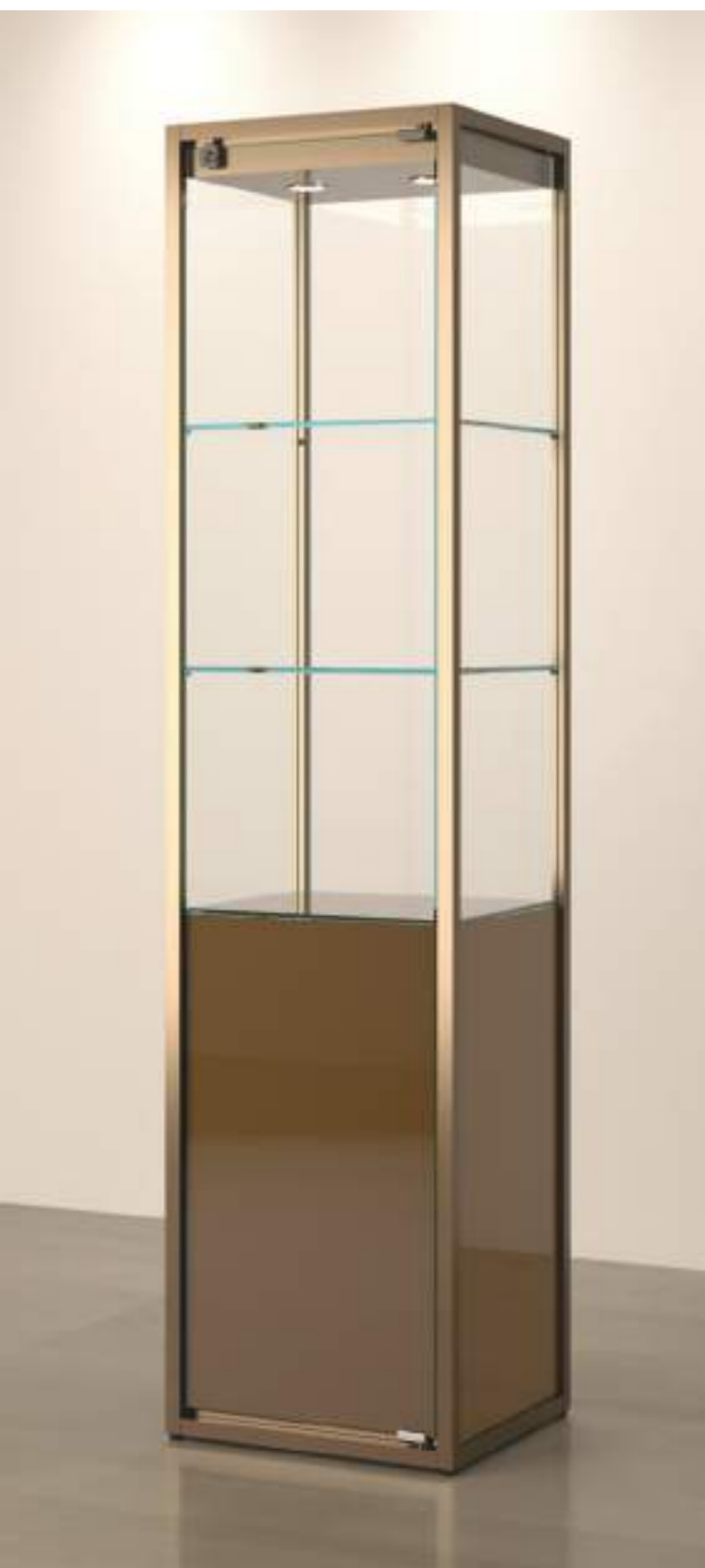

art. **TM/45VM** (cm 45x45x190h)
Ripiani Regolabili - *Adjustable shelves*



art. **TM/75VM** (cm 75x45x190h)
Ripiani Regolabili - *Adjustable shelves*



art. **TM/95VM** (cm 95x45x190h)
Ripiani Regolabili - *Adjustable shelves*



TAVOLI&BANCHI



TAVOLI&BANCHI



art. 80/BA (cm 120x60x90h)



Esempio del art. 80/BA con top art. 21/RE
Example of art. 80/BA with glass top art. 21/RE



art. 21/Q (cm 120x120)
piano per tavoli in cristallo - crystal top for tables

art. 31/L (cm 40x40x77h)
base in cristallo - crystal base

art. 31/LA (cm 40x40x97h)
base in cristallo - crystal base

VETRINE ED ESPOSITORI PROMOZIONALI
PROMOTIONAL DISPLAYS

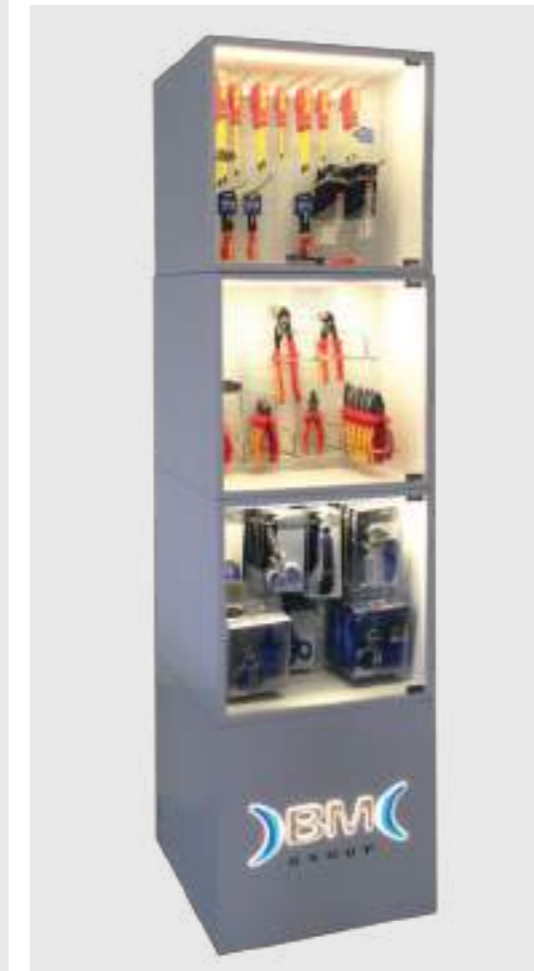
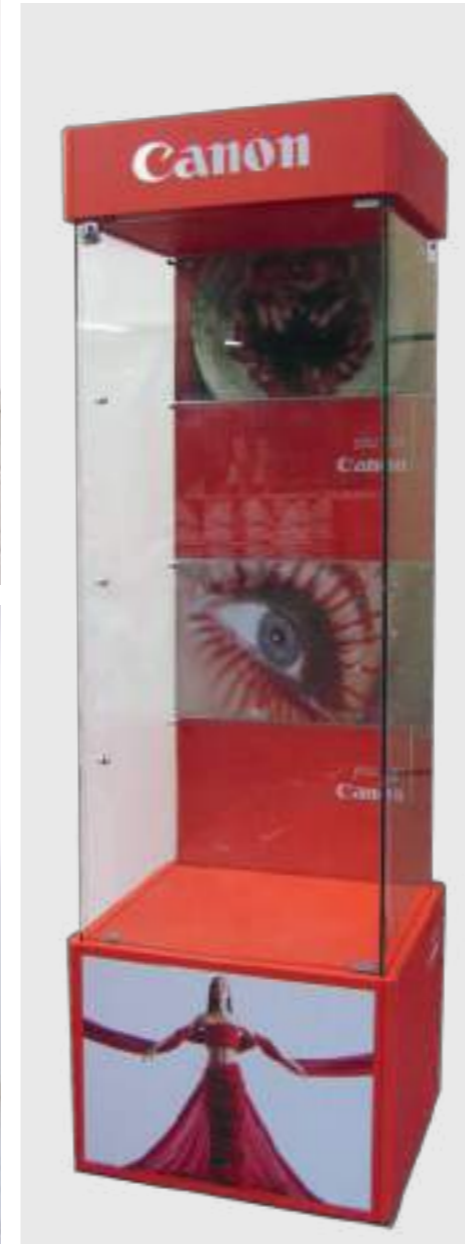
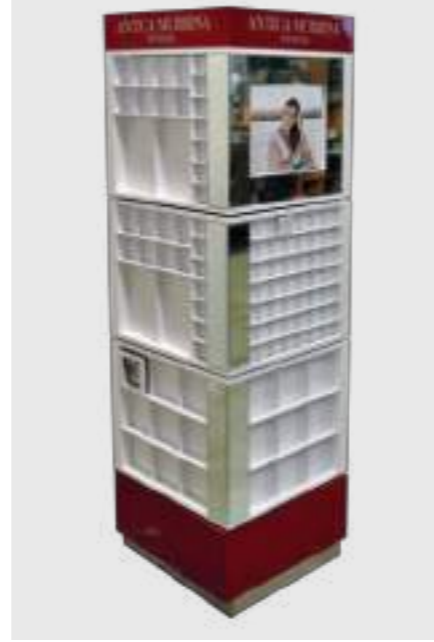

Specials

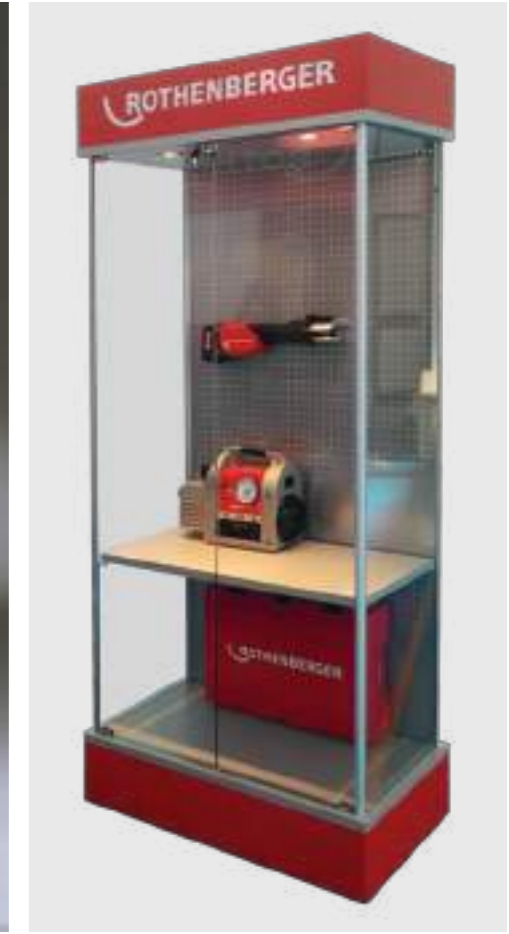

Specials



PANTIC
CARLO GHAZZI

ROC

FIDENZA
IDEE IN VETRO

urmet

VICTORINOX

VISA

CITIZEN

MORINI

OSMAN

OSRAM

MITSUBISHI

PIONEER

IMETEC

ARORA

TEXAS
INSTRUMENTS

TRUSSARDI

roadstar

AUTO - HIFI

ZEN

Colombini

DomusOro

VICTORINOX
SWISS ARMY

Chadaa

G.BANDINI
RUBINETTERIE

kms
CALIFORNIA

KASARTE

Kronos

*bes
BAIT & DING

KONIG
ELECTRONIC

jhc HOYA

FLAEM

LACOSTE

PARKER

TAVÈCCHI

sanoform

rotring

ROHL
MOOR

WATERMAN

SAMSUNG
CAMERAS

Schuco

witox
WOLFRUMBERG TOOLS

L'ORÉAL
PARIS

LACOSTE



Specials





Specials





ACCESSORI **OPTIONAL**

- DI SERIE / STANDARD
- OPZIONALE / OPTIONAL
- ☒ NON DISPONIBILE / NOT AVAILABLE





ARTICOLO DESCRIZIONE

	LAMINATO light	LAMINATO	Alldesign®	Alldesign+ plus	TopLine 2	TopLine 9	QUADRATUM frame	QUADRATUM	MUSEUM	GLASSystem®	black & white	GLASSY
 <p>ART. PA GUARNIZIONE ANTIPOLVERE. ANTI-DUST PROFILES.</p>	●	●	●	●	●	●	●	●	●	☒	●	●
 <p>ART. SA SERRATURA ANTA SINGOLA. LOCK FOR SINGLE DOOR.</p>	●	●	●	●	●	●	●	●	●	☒	●	●
 <p>ART. SA/2 SERRATURA ANTA DOPPIA. LOCK FOR DOUBLE DOORS.</p>	●	●	●	●	●	●	●	●	●	☒	●	●
 <p>ART. SC SERRATURA A CREMAGLIERA PER SCORREVOLI. RACK LOCK ON GUIDE.</p>	●	●	●	●	●	●	●	●	●	☒	●	☒
 <p>ART. SS SERRATURA A SPILLO PER SCORREVOLI. PIN LOCK ON GUIDE</p>	●	●	●	●	●	●	●	●	●	☒	●	☒
 <p>LUCI ALOGENE NEL TOP. HALOGEN TOP LIGTHS.</p>	●	●	●	●	●	●	●	●	●	●	●	●
 <p>LUCI LED NEL TOP. LED TOP LIGTHS.</p>	●	●	●	●	●	●	●	●	●	●	●	●
 <p>LUCI ALOGENE LATERALI. HALOGEN SIDE LIGTHS.</p>	●	●	●	●	●	●	●	●	●	●	●	●
 <p>LUCI LED LATERALI. LED SIDE LIGTHS.</p>	●	●	●	●	●	●	●	●	●	●	●	☒

ARTICOLO DESCRIZIONE

LAMINATO *light*
 LAMINATO
ALLdesign
ALLdesign+
 plus
TopLine
TopLine
 QUADRATUM
 QUADRATUM
MUSEUM
 GLASSystem
black & white
GLASSY

	ART. CS/92 - CS/140 - CS/180 CASSE SPECIALI RIUTILIZZABILI. SPECIAL CRATES TO BE RE-USED.	●	●	●		●	●	●	●	●	●	●	●	●
	ESEMPIO DI CASSA IMBALLO STANDARD. EXAMPLE OF STANDARD PACKAGING CRATE.	●	●	●		●	●	●	●	●	●	●	●	●
	ART. MT MOTORE PER VETRINE GIREVOLI. MOTOR FOR ROTATING SHOWCASES.	●	●	☒		☒	●	●	●	●	☒	●		☒